

# VideoDR-S User's Manual

*User's Manual version 1.12 (May 2003)  
This manual applies to the program version 1.0.0.249*

© 2003 ALNET SYSTEMS INC.

---

*The information in this manual is up-to-date at the moment of this publication. ALNET SYSTEMS, INC.. has all rights to modify the program without earlier notification.  
This manual applies only to the VideoDR-S server application.*

## Table of contents

<b>1</b>	<b>INTRODUCTION .....</b>	<b>4</b>
1.1	SYSTEM DESCRIPTION .....	4
1.2	VIDEO CAPTURE CARDS .....	4
1.3	HARDWARE AND SOFTWARE REQUIREMENTS .....	5
1.3.1	<i>Minimum requirements .....</i>	<i>5</i>
1.3.2	<i>Recommended configuration .....</i>	<i>6</i>
1.3.3	<i>What hardware to avoid? .....</i>	<i>6</i>
<b>2</b>	<b>INSTALLATION OF THE VIDEODR-S SYSTEM ON A PC.....</b>	<b>8</b>
2.1	INSTALLATION OF VIDEO CAPTURE CARDS.....	8
2.2	INSTALLATION OF THE DONGLE .....	8
2.3	CONNECTION OF CAMERAS, SWITCHES AND ALARM INPUTS .....	9
2.4	INSTALLATION OF THE SOFTWARE .....	10
<b>3</b>	<b>STARTUP AND CONFIGURATION OF THE VIDEODR-S SYSTEM .....</b>	<b>16</b>
3.1	RUNNING THE PROGRAM FOR THE FIRST TIME .....	16
3.2	FIRST CONFIGURATION – STEP BY STEP .....	17
3.3	MAIN PROGRAM VIEW .....	18
3.4	SCREEN DISPLAY MODES, BOOKMARKS, SAVING A FRAME FEATURES .....	22
3.4.1	<i>Sequence of displaying camera images and saving a frame .....</i>	<i>22</i>
3.4.2	<i>Window display modes (full screen, window, normal).....</i>	<i>23</i>
3.4.3	<i>Split screen modes (screen layout).....</i>	<i>23</i>
3.4.4	<i>Bookmarks.....</i>	<i>23</i>
3.5	CONFIGURATION OF CAMERA SETTINGS .....	23
3.6	CONFIGURATION OF THE VIDEO CAPTURE CARD .....	29
3.7	CONFIGURATION OF PROGRAM SETTINGS .....	30
3.8	CONFIGURATION OF NETWORK SETTINGS – VIDEO SERVER .....	31
3.9	CONFIGURATION OF ARCHIVE FILES .....	32
3.10	CONFIGURATION OF SERVER ACCESS ACCOUNTS.....	33
3.10.1	<i>Editing an account.....</i>	<i>34</i>
3.10.2	<i>Adding a new account.....</i>	<i>37</i>
3.10.3	<i>Deleting an account.....</i>	<i>37</i>
3.11	CONFIGURING DNS SERVICE .....	37
<b>4</b>	<b>USING THE VIDEODR-S SYSTEM .....</b>	<b>39</b>
4.1	BROWSING THE VIDEO IMAGE ARCHIVE.....	39
4.1.1	<i>Control panel of the archive.....</i>	<i>40</i>
4.1.2	<i>Searching for motion in image archives.....</i>	<i>41</i>
4.1.3	<i>Exporting archive to AVI file.....</i>	<i>42</i>
4.1.4	<i>Inserting the bookmark into the video archive.....</i>	<i>43</i>
4.1.5	<i>Zooming into fragments of the image .....</i>	<i>43</i>
4.1.6	<i>Setting the archive image parameters and motion detection sensitivity...44</i>	<i>44</i>
4.1.7	<i>Scaling the time charts.....</i>	<i>44</i>
4.1.8	<i>Browsing recordings from a given day – using the calendar.....</i>	<i>44</i>
4.2	SCHEDULER .....	45
4.2.1	<i>Camera Operation Schedule (motion detection alarm).....</i>	<i>45</i>
4.2.2	<i>Input Operation Schedule .....</i>	<i>47</i>

---

4.2.3	System alerts .....	48
4.3	SELECTING AND ADDING NEW EMAIL ADDRESSES .....	49
4.4	CREATING A BACKUP COPY OF THE VIDEO IMAGE ARCHIVE .....	50
4.5	UPDATING THE PROGRAM .....	51
4.6	"ABOUT" WINDOW .....	52
4.7	EXITING THE PROGRAM.....	53
4.8	LOGIN AND LOGOUT OPTIONS .....	53
<b>5</b>	<b>DOMES CONTROL .....</b>	<b>54</b>
5.1	DOMES CONTROL SETTINGS.....	54
5.2	DOMES CONTROL PANEL.....	56
<b>6</b>	<b>DONGLE VALIDATION .....</b>	<b>57</b>
<b>7</b>	<b>UNINSTALLATION OF THE VIDEODR-S SYSTEM SOFTWARE .....</b>	<b>60</b>
<b>8</b>	<b>FAQ - FREQUENTLY ASKED QUESTIONS.....</b>	<b>61</b>
<b>9</b>	<b>ADVANCED SETTINGS .....</b>	<b>63</b>
9.1	TUNNELING .....	63
9.2	DIAL-UP .....	63
<b>10</b>	<b>CONTACT INFO .....</b>	<b>65</b>

# 1 Introduction

The digital technology successfully conquers many fields of life where it has been used only marginally until now. This is happening thanks to continuous technological progress and development of new algorithms. Employment of new technologies and methods for digital image recording and compression, decreasing prices of mass memory units and faster processors, contributed to development of modern closed-circuit television systems, the best of which is currently the VideoDR-S system.

## 1.1 System description

The VideoDR-S is a digital video recorder designated for operation with closed-circuit television cameras. The system runs on IBM-compatible computers with Microsoft Windows 2000 or Microsoft Windows XP operating system. It can record the image from a maximum of **16 cameras**, supports up to **12 remote switches** and **16 inputs** for additional **alarm inputs**. It allows inspection and **control through a computer network** (e.g. the Internet). Pro version and above allows for **PTZ domes** control. The program permits setting of **motion detection** in arbitrary areas of the screen, as well as **motion searching** in archives. The **differential image-compression method**, while preserving excellent image quality, allows image recording longer than in other systems of this type, at the same file size. The differential image-recording algorithm used does not replace the entire new frame but only its part that has changed. The replaced image fragments are called **deltas** in the system.

**Home Edition** version is designed for households and is limited in comparison with Professional edition. The limitations are as follows:

- alarm inputs and remote switches not supported,
- there might be only one administrator and regular user in the system,
- 3 fps per camera limited frame rate capture,
- remote access only to current day archives,
- no scheduling feature.

**Real Time** version supports video capture in real time. Maximum 30fps per each camera for NTSC TV system and 25fps for PAL TV system.

The software used for operation of the VideoDR-S comprises two independent programs. The first of them is a server application, operating the video capture card and related processes. The second is a client application used for connecting to the server through local networks or the Internet. The server includes all the client options and tools for the computer on which it is installed and running. The installation version is comprised of two separate executable files – for the client and the server. The optional client application is free of charge, and it allows remote management and browsing of data made available by the server. The video archive of the server may also be browsed remotely by the client application.

## 1.2 Video capture cards

The video capture cards are extensions of the motherboard, placed inside the computer case, plugged into **PCI** slots of the motherboard. A single card includes four **BNC** standard terminals used for input of video signal from cameras, and a serial

interface used for connecting up to four alarm signals as well as 3 devices to be controlled by the card (3 relays). The system can operate up to 4 cards.

The basic element of a single card is the BT878 processor used for conversion of video input signal into digital form. This processor is capable of capturing up to 25 frames per second. Connecting 4 signals to one converter (a card with one converter) gives a computing power resulting in 7 frames per second for each of the four active video inputs of a single card. When only one video signal input of a one-processor card is active, it is possible to convert this signal with the speed guaranteed by the BT878, which is equal to 30 frames per second (25 for PAL system).



We have another video capture card that is used for Professional Real Time version. It has four BT878 processors. You can connect 4 or 8 cameras to this video capture card and have up to two cards in one device. If you use one capture card you could have captured **30 fps** per each camera.

### 1.3 Hardware and software requirements

For failure-free operation of our systems we recommend using processors and motherboards based on the **Intel** chipset.

#### **NOTE!!!**

The VideoDR-S has been designed for continuous operation under **Microsoft Windows 2000** or **Microsoft Windows XP** operating systems. VideoDR-S will not work with other operating systems (e.g. Windows 95/98/Me, BeOS, Linux...).

#### 1.3.1 Minimum requirements

The recommended minimum is a computer with:

- 256 MB of RAM,
- large capacity hard drive (20Gig +)
- graphics card with 32 MB of RAM (e.g. based on the GeForce2 graphics processor),
- monitor supporting 1024x768 resolution.

Depending on the number of cards installed, the following processors are recommended:

- Intel Celeron 1.0 - 1.2 GHz (256 kB Cache) – one card,
- Intel Celeron 1.3 - 1.4 GHz (256 kB Cache) – two cards,

- Intel Celeron 1.3 - 1.4 GHz (256 kB Cache) – three cards,
- Pentium IV 1.8 MHz and better – four cards.

We recommend the Intel chipset of the motherboard to fully utilize the PCI bus speed. For 1 to 3 card systems – i815, for 3 to 4 cards – i845 or i850.

### 1.3.2 Recommended configuration

- **Pentium 4** class processor for optimal operation of the entire system,
- **512 MB** of RAM,

Motherboards based on Intel chipsets: 815E/815EP (PIII), 845(P4), 845D(P4), 845E(P4), 845G(P4).

#### **Recommended motherboards:**

- ASUS P4B
- ASUS P4B266
- ASUS P4B533
- ASUS P4B533-V
- GIGABYTE 8IRX
- GIGABYTE 8IEX
- GIGABYTE 8IEXP
- GIGABYTE 8IGX
- MSI 845E Max2
- MSI 845G Max
- MSI MS-6337
- ABIT-SA6R
- ICP Rocky-4784EVB
- ASUS TUSL2-C (PIII / Celeron)
- AXIOM SBC8168VE

**(Motherboards based on VIA/SiS/Ali chipset are not recommended)**

**PCI slot expansions:** 1 / 2 / 3 / 4 × 32-bit PCI 2.1

#### **RAM:**

- Transcend DDR 256MB (DDR-266)
- KingSton DDR 256MB (DDR-266)
- KingMax SDRAM 256MB (PC-133)
- KingMax DDR 256MB(DDR-333)

**Graphic cards:** 16-bit color with DirectDraw support

Recommended graphic cards:

- Leadtek WinFast GeForce2 MX400
- Leadtek WinFast A170 DDR TDH
- Leadtek WinFast 3D S325 32MB
- Leadtek WinFast A250 TD 128MB
- ATI RADEON 8500 64MB/128MB
- ELSA GLADIAC 525 128MB
- ELSA GLADIAC 517 VIVO 64MB

### 1.3.3 What hardware to avoid?

- Motherboards with an onboard/integrated graphics card.

- Motherboards **not based** on the Intel chips.

## 2 Installation of the VideoDR-S system on a PC.

The following paragraphs outline step-by-step instructions for installation of the hardware dongle, video capture cards and VideoDR-S system software.

### 2.1 Installation of video capture cards

Depending on the selected kit, one to four video capture cards are delivered, together with the hardware "dongle" and the software operating with the specified number of cards.

In the first step of the installation process, ensure that the computer is switched off, then remove the screws and remove the left side panel of the PC case (looking from the front) and insert all video capture cards into available PCI slots<sup>1</sup>

PCI slots

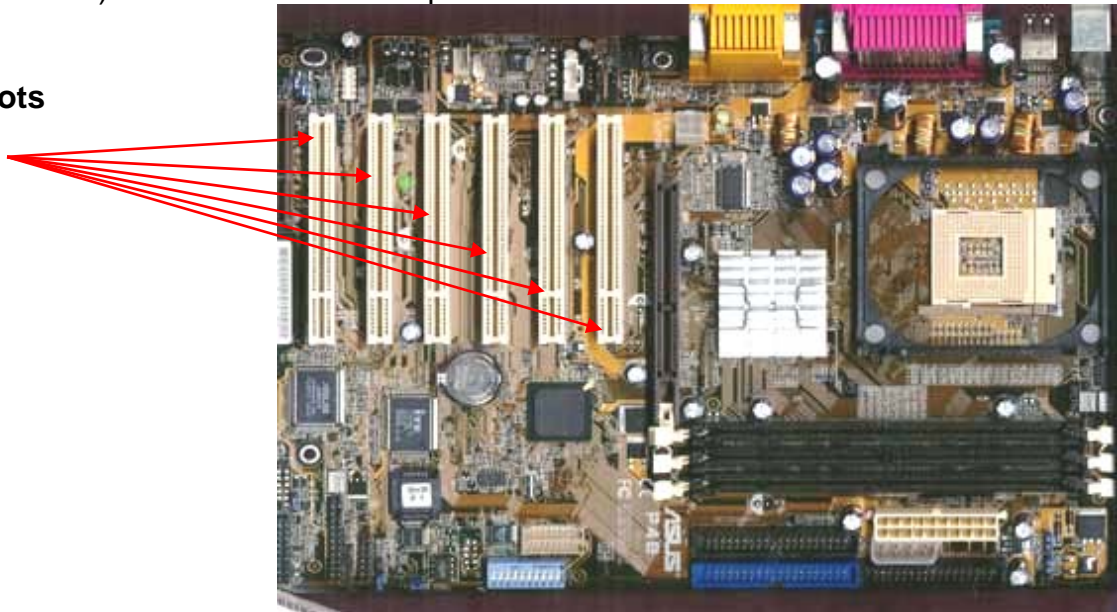

Placing the case horizontally will allow easy access to the motherboard. Insert video capture cards into successive available slots. After inserting all the video capture cards replace the side panel and fasten the screws.

### 2.2 Installation of the dongle

For the software to operate correctly, the hardware dongle must be installed.



LPT dongle



Guardant and HASP USB dongles

Plug the dongle into the printer parallel port (LPT) or USB port at the back of the computer. The computer can now be switched on and the software installed.

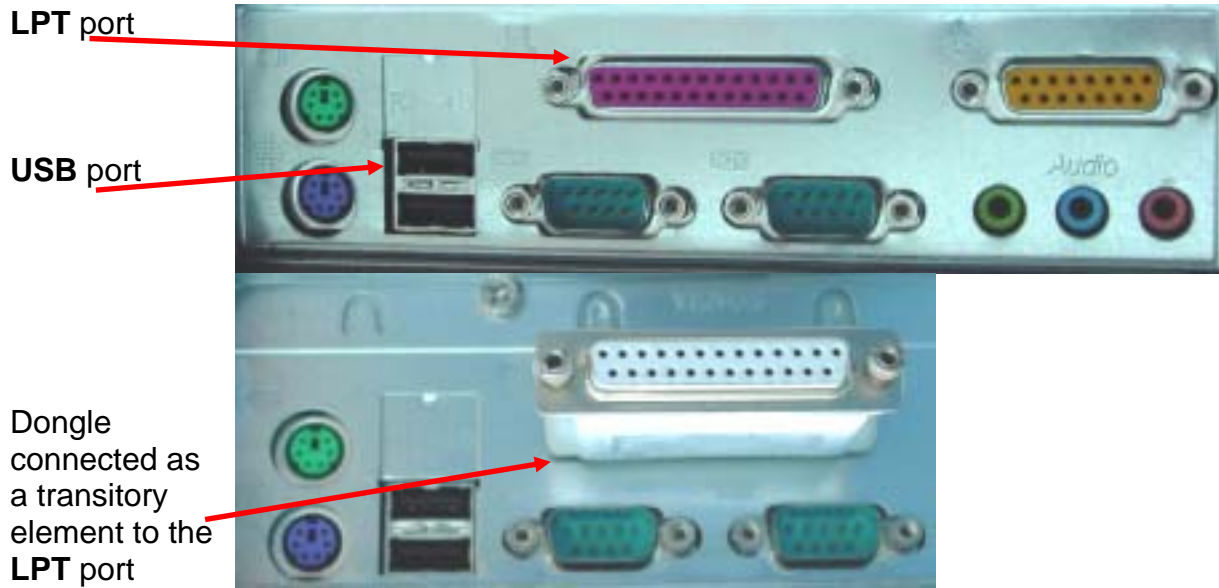

### **2.3 Connection of cameras, switches and alarm inputs**

Connect the cameras, plugging the BNC plugs from the cameras into the BNC sockets on the video cards in the computer. Ensure that the cameras are powered on.

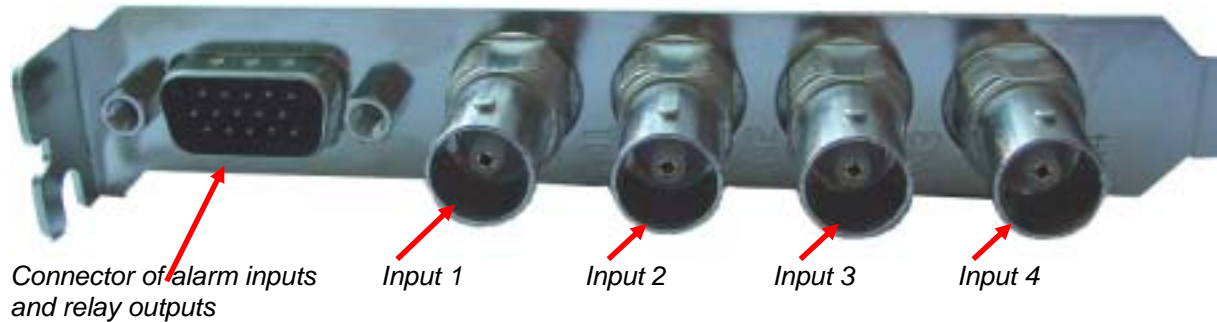

The connection of a suitable cable to the 15-pin connector of a given video card accommodates connection of switch outputs and additional sensor inputs. Using this connector, you can connect 4 additional alarm sensors and 3 switch outputs to each card. Two relays are SPST type, and one is SPDT type. A pin layout of the connector is presented below:

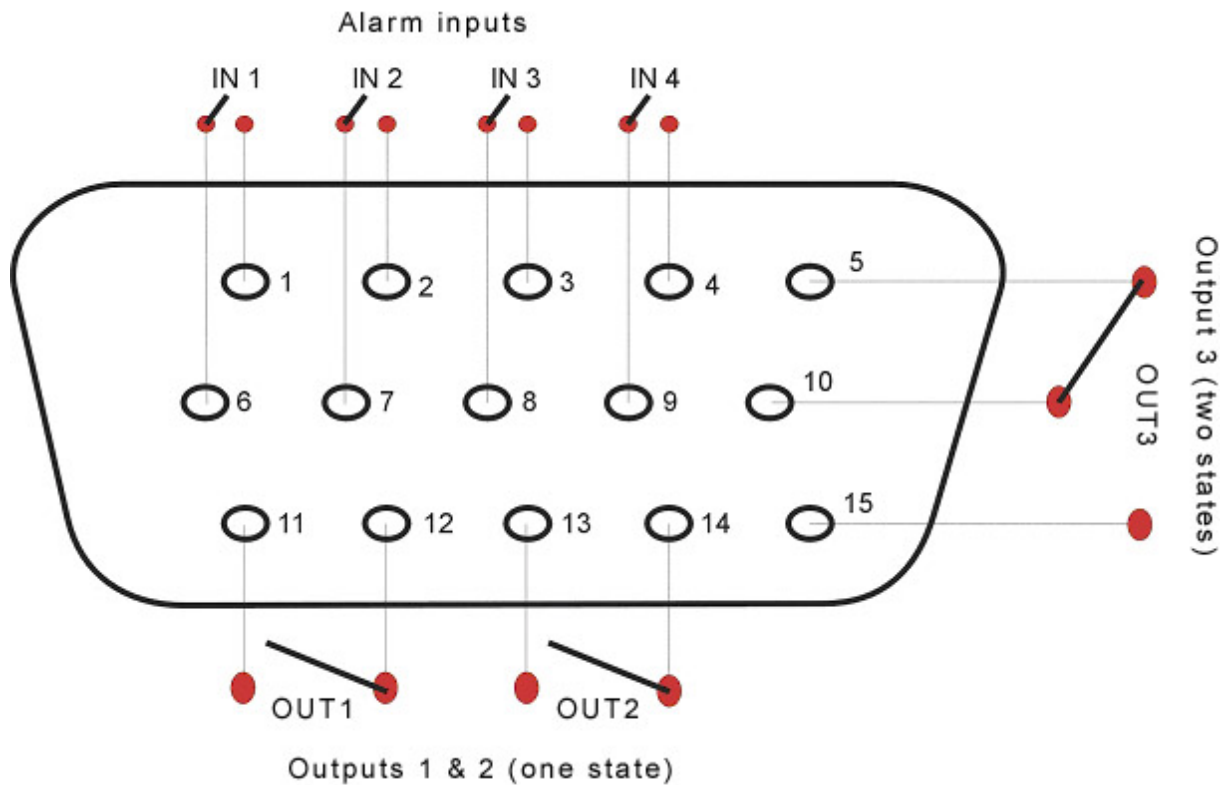

## 2.4 Installation of the software

At the startup, the Windows operating system should recognize a new device in the computer (the installed video capture cards).

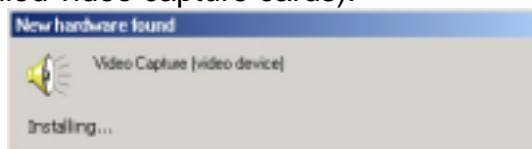

The system will ask if you want to install drivers for the new **Video Capture** device in the system. Leave this window open (do not click any of the buttons) and begin the installation of the VideoDR-S software.



After the startup, the installation program will display a welcome screen, prompting you to install the software for the VideoDR-S system. Press the **Next** button :



The next screen will display information concerning the license to be accepted by the user. Clicking the **Yes** button confirms the acceptance of license and conditions offered by the software manufacturer.

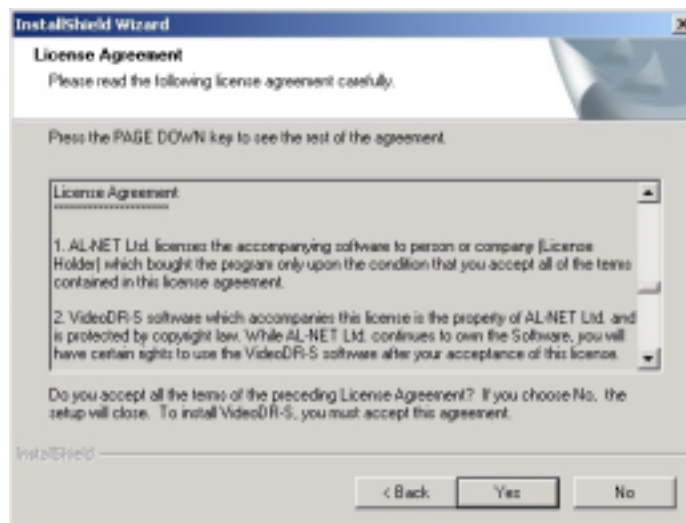

The next window displayed will ask for the user name and company name to whom the product will be registered. The *First name* and *surname* of the user, as well as the *Company name*, must be entered in respective fields in order to proceed with the software installation.

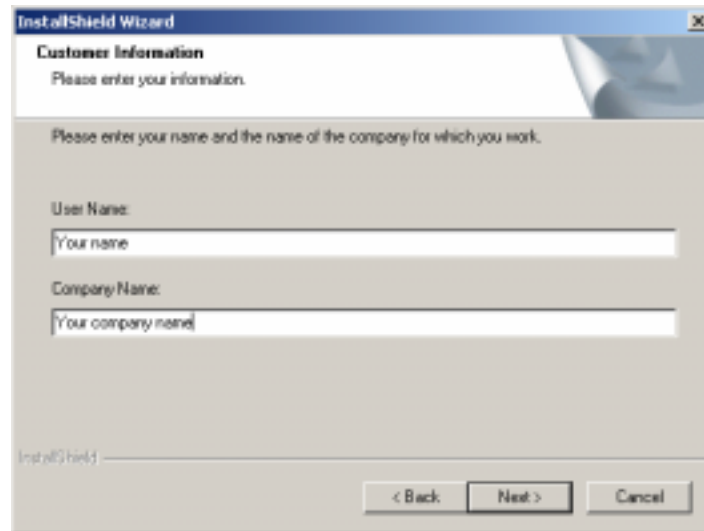

The program will ask you to choose a target location. You can accept the default settings or chose another location by clicking the browse button. Press the **Next** button to proceed.

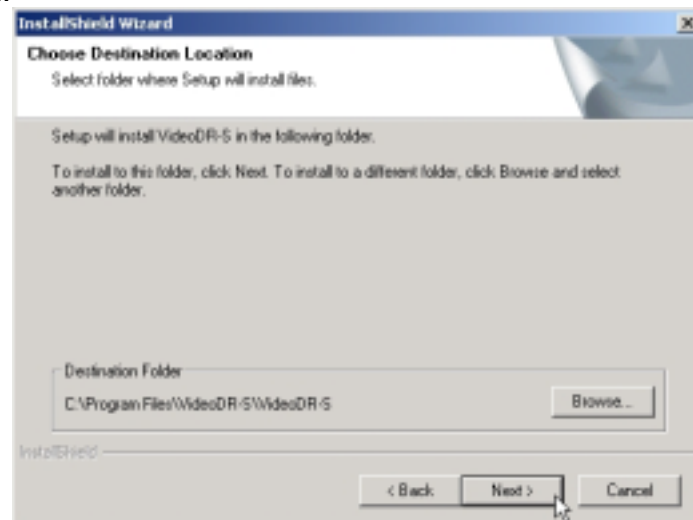

In the next step you will be asked for a target folder in the *Start* menu of Windows system. The default folder is *VideoDR-S*. You may accept the default or specify another location.

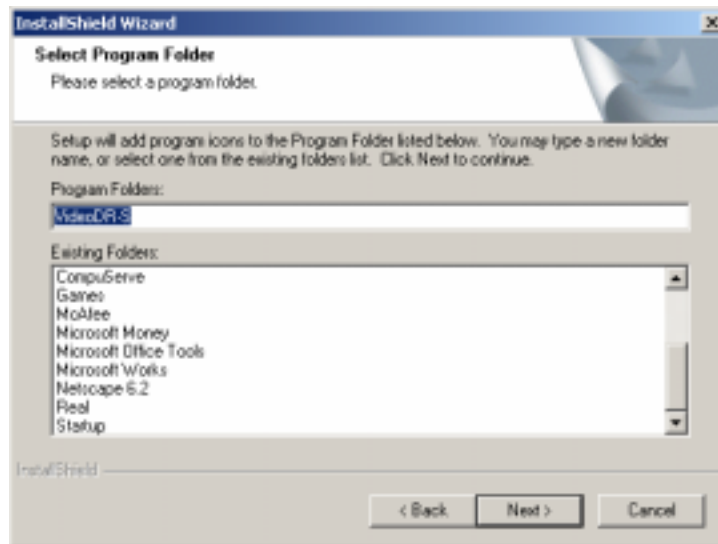

A message stating “**Dongle driver installed**” will confirm successful installation of the software.



The last window will remind you, that it is necessary to install the video capture card drivers, providing the cards are already installed in the computer.

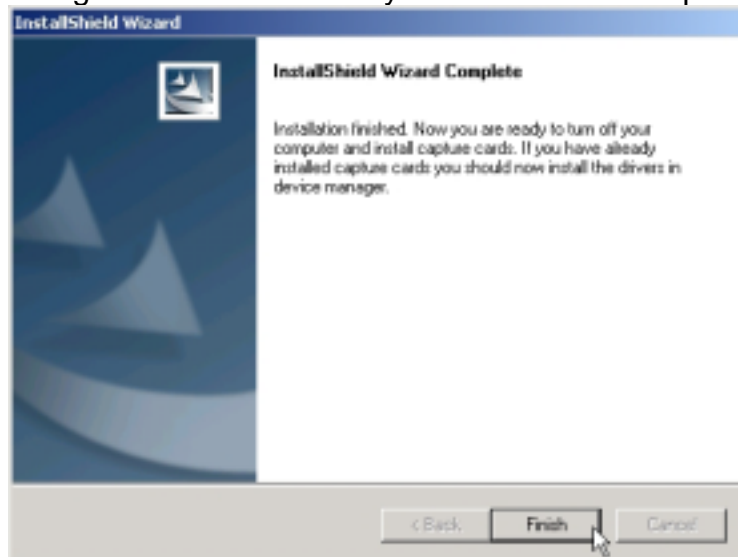

Start the Microsoft Windows **Add/Remove Hardware Wizard**. Press the **Next** button in this window and the system will automatically find drivers for the installed video capture cards. Windows XP will display a message warning about missing Microsoft digital certificate signatures for the drivers. Select the **Continue anyway** option.

An alternative method to open the **Add/Remove Hardware Wizard** is via **Device Manager** in the **Control Panel**. Right mouse-click **Sound, video and game controllers** from the device list and select the option **Scan for hardware changes**.

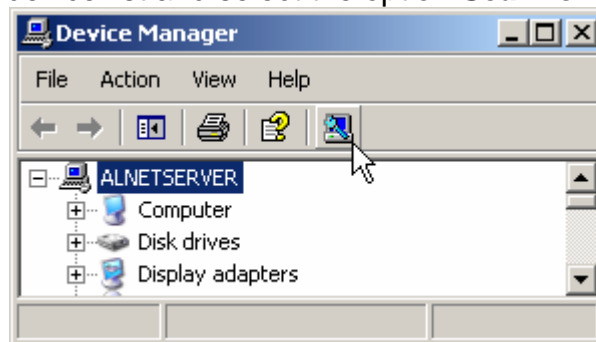

Follow the steps in the **Add/Remove Hardware Wizard** to proceed with installation.

1.

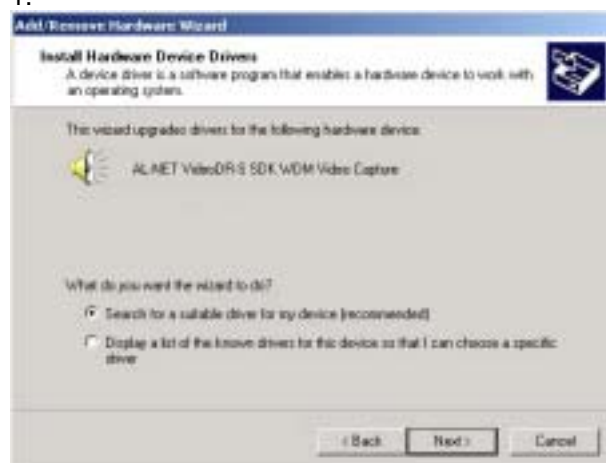

2.



3.



4.



Install the driver for the audio capture device. If you have more than one card, you will have to repeat the above steps for each one.

In order to ensure that the video card drivers have been installed correctly, you can check if they appear without error or warning note in the **Device Manager** listing. You should find drivers installed as per the following screenshot.

**ALNET VideoDR-S WDM Video Capture and,  
ALNET VideoDR-S WDM Audio Capture.**

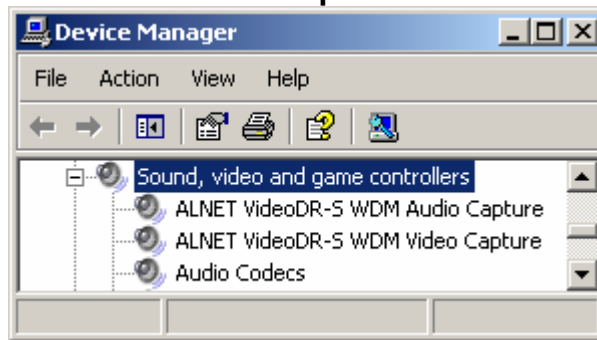

A shortcut to the program will be created by default on the Windows desktop. Start the VideoDR-S system, by clicking the **Start DR-S** shortcut on the desktop or by selecting it from the Start menu. The VideoDR-S program is now ready for configuration.

### 3 Startup and configuration of the VideoDR-S system

To start the program, click the **Start DR-S** icon on the Windows desktop or select the program from the Start menu, **Start / Applications / ALNET** or the alternative location chosen during installation. By default the VideoDR-S starts automatically with Windows. A program monitoring agent detects any operating system failure or other problem and will require the digital video recorder to be restarted.

#### 3.1 Running the program for the first time

The program started for the first time displays a window asking for selection of the user interface language and cameras' TV system (**NTSC** or **PAL**). Select the **language** from the drop-down list and press OK.

In next step you will be prompted for entering the program license number that could be found in the supplied package.

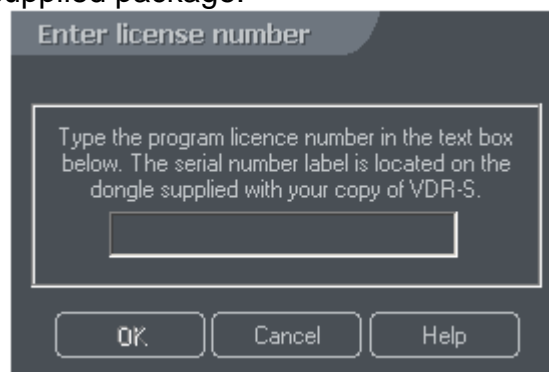

Enter the number and press **OK**. If you cannot find the number you should contact the distributor or manufacturer but for the time being you can click **Cancel** and program will run. An hour later after you clicked the Cancel you will be prompted again for entering the license number. You can always do it by selecting menu **About** and then click **Enter license number**.

The next window is the warning message:

*Warning: No archive recordings found. Recording/Playing will not be possible.*

This is a reminder to configure the database for recording (description in Chapter 3.9).

The program will now ask for a new user name and password. This new user ID will have **administrator status and rights**.

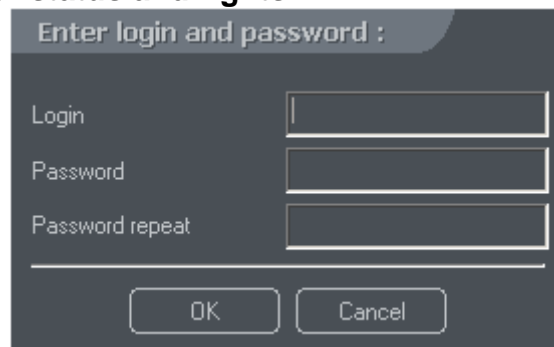

**NOTE!!! Remember the user name and the password of the administrator, as it is necessary to use this login until other users with administrative rights**

**are created.** Creating other user accounts and editing existing accounts is described in Chapter 3.10.

When running the program in the future, it is necessary to enter a valid user name and password.

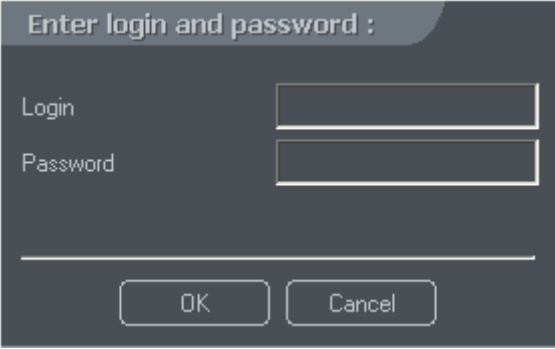
A screenshot of a login dialog box. The title bar reads "Enter login and password :". Below the title bar, there are two input fields. The first is labeled "Login" and the second is labeled "Password". At the bottom of the dialog box, there are two buttons: "OK" and "Cancel".

Initial configuration is required the first time the program is started.

### **3.2 First configuration – step by step**

1. **Camera Settings.** Set the quality of the recorded image and the sensitivity of the changed fragments replacement. You can mask an area, decide when the image should be recorded and set the motion detection threshold. Additionally, you can select the color of displayed texts and set other personal preferences. More functions of individual elements of the window are described in Chapter 3.5.
2. You can also select the required resolution of image recording, as necessary. The higher the resolution, the better the image quality, but it results in a reduced frame per second rate and also larger files. For settings see Chapter 3.6.
3. Before starting the recording you have to create video archive databases. Here you select archive files size and disk space thresholds and locations. Description in Chapter 3.9.
4. If you want to configure the VideoDR-S as a video server, in order for the client application to connect to it through a network, you have to activate the video server. See Chapter 3.8. It is good practice at this point to create an additional user in the system, especially for the remote connection, due to security considerations such as insecure connections. Remember to assign access rights for cameras, the archive, time, domes, etc. More details are in Chapter 3.10.

Below you can find a description, appearance and functions of individual elements in the view of main window of the VideoDR-S system.

### 3.3 Main program view

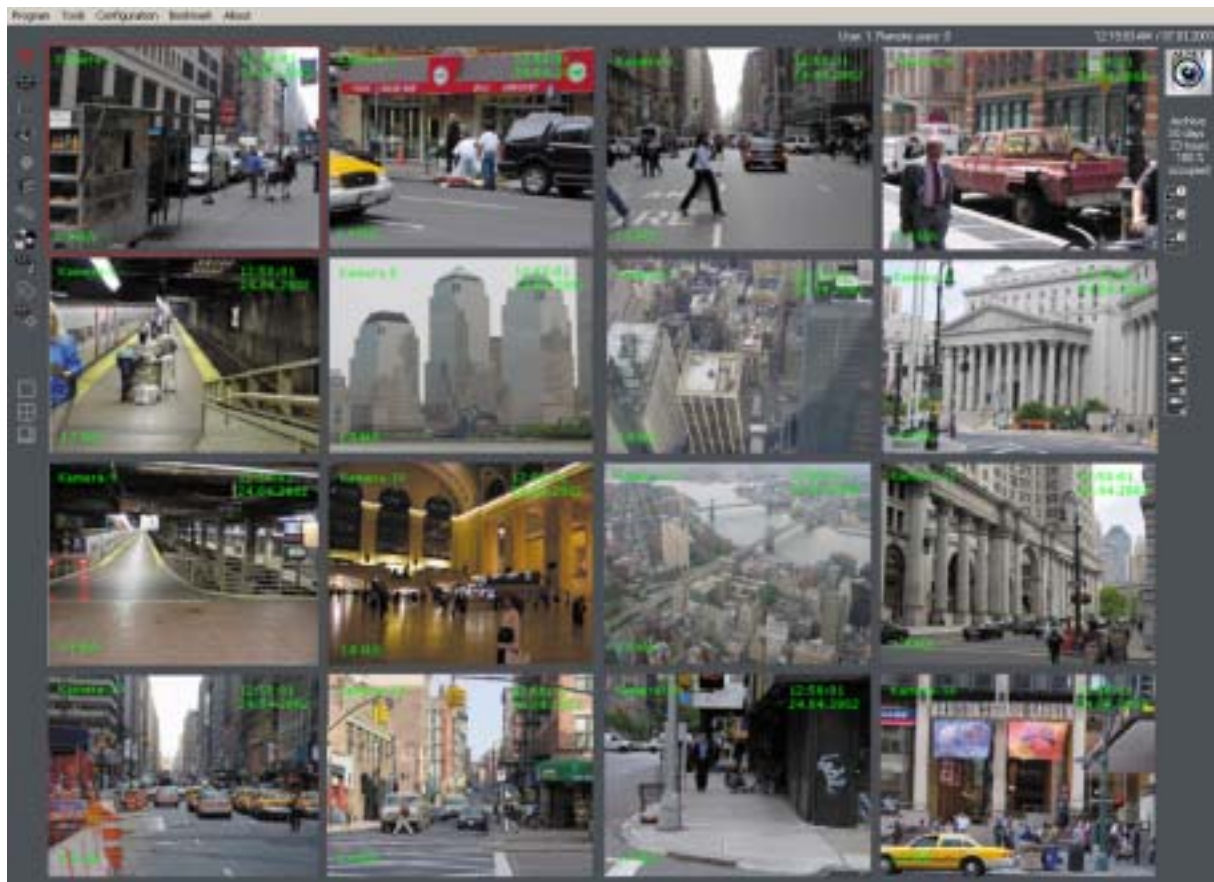

The toolbar at the top of the screen contains a drop-down menus giving access to the most important options of the system.

- **Program** menu:
  - **Minimize** – minimize the window to an icon in the taskbar
  - **Login** – switch to another user without needing to restart the program
  - **Exit** – exits the program. While closing, the application prompts you to save any configuration changes to the configuration file. If you close the application for the first time, you have to specify the configuration file location.
- **Tools** menu:
  - **Browse archives** – go to the archive of video recordings.
  - **Schedule** – run program tasks at scheduled time
  - **Backup** – archive the folders with video recordings.
  - **Register domain** – a utility to register for the dynamic DNS service
  - **Configuration tools**
    -
  - **Program update** – see the newest versions of the program on the Internet, download and install a new version of the program.
- **Configuration** menu:
  - **Cameras** – go to a camera configuration window.
  - **Capture cards** – configuration of the image capture cards.

- **Network** – settings of remote access to the server through a computer network (e.g. the Internet).
- **Archive** – go to the archive of video recordings.
- **User accounts** – go to user accounts settings.
- **Domes** – settings of the domes controlling methods.
- **Program settings** – go to program settings.
- **Bookmarks**
  - **Add bookmark in archives** – this option lets you add a bookmark in the archives.
- **About**
  - **About VideoDR-S** – displays information about the manufacturer and program version.
  - **Enter license data** – appears only if you haven't registered your copy yet. It will open the window where you can enter the license number.

The following screenshot shows some of the most important elements of the system, i.e. views from cameras, information about the name of the camera, the date and the number of captured frames per second.

Camera name













Number of captured frames per second



Current time and date

The user name, the time and the number of days recorded in the archive, as well as the number of remote users connected, are displayed in the upper right corner of the window.

On the left side there are icons allowing direct access to desired configuration functions of the program, and to switch the camera views.

	Turn the recording on / off.
	Camera Settings.
	Browse the video archives.
	Settings of the video cards.
	Settings of remote access to the server through a computer network (e.g. the Internet).
	Settings of access to the mass storage of the computer. Specification of the archive locations.
	Settings of the server parameters.
	Configuration of user accounts for remote access.
	Scheduler – controlling the program behavior depending on activation of alarm inputs of the system, detection of motion by the cameras, or system events. <b>NOTE! Option not available in the Home Edition version</b>
	Dome control – <b>NOTE! Option not available in the Home Edition version.</b>
	Allows setting the joystick and the keyboard for controlling the camera domes. Detailed description in Chapter 5.
	Dome control panel – <b>NOTE! Option not available in the Home Edition version.</b> Virtual joystick, if no joystick has been connected then you can control dome movements using this panel. Detailed description in Chapter5.
	Options to change the camera view. Divide the screen in a layout as shown on the icon.

The right side of the screen contains icons representing switches and sensor inputs of the video cards. Clicking a particular icon causes activation of that switch and a change in the icon appearance.

	Switch icons. Every video card has 3 built-in switches; therefore the system can operate a maximum of 12 switches. Click a switch with the mouse pointer to toggle on or off. On the image to the left the switch # 1 is on, and the other two switches are off. A switch may, for example, turn on the light in a room. Right-click on a switch icon to call up the <b>Output parameters</b> window. <b>NOTE! Option not available in the Home Edition version</b>
---	---

Settings:

- **Name** of the output.
- **Active state** – determines which output state will be the active state upon switch activation (NC – Normal Closed, NO – Normal Open).

Event switching:

- **Triggered** – the switch will be activated for the duration of the input signal associated with this switch (as configured in the Scheduler). The **hold for** setting will hold the switch state for the specified number of seconds independent of the input state setting.
- **Pulsate** – Selecting this option will cause the output to be activated every second, causing pulsation of the signal.

Manual switching:

- **Auto switch off** – the switch signal will be switched off automatically after the specified number of seconds.



Alarm input icons. **NOTE! Option not available in the Home Edition version** Every card has 4 built-in alarm inputs, which gives a maximum of 16 independent additional sensors operated by the system.

Left-Click an icon to change the name of an alarm input. To set the program behavior in response to the activation of a particular alarm input use the

**Scheduler** window opened via the upper menu **Tools** or pressing the  icon in the left menu.

Right-click an icon to call up the settings window.

In the input settings you can specify the **Name** of the input, and which state is the **Active state**, i.e. alarm activation.

It is also possible to associate a **.WAV** sound file with a particular input (a suitable **computer soundcard must be installed**).

You can then specify what will happen **After activation** of the alarm input:

- **Send Email** – Enter valid email addresses to receive customized email messages. Message contents can include images from selected cameras. Click to call up a window enabling entry of email addresses and displaying an address book – see Chapter 4.3.
- **Add bookmark** – mark the time chart with the event using the bookmarks.
- **Set outputs** – select which outputs are to be triggered by a specified input.
- **Sound** – select this option to activate an audible alarm triggered by a specified input.

### 3.4 Screen display modes, bookmarks, saving a frame features

#### 3.4.1 Sequence of displaying camera images and saving a frame

Images from the cameras are displayed on the screen in sequence. You can switch the views using the screen division icons located in the lower left part of the main view. You can change the sequence of images on the screen by *dragging and dropping* the images. You can accomplish the same thing by clicking a camera view with the right mouse button and selecting a camera view from the drop-down **Visible camera** context menu.

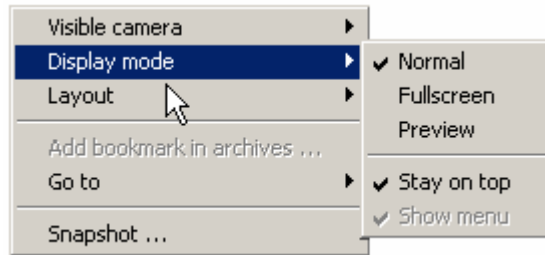

Use **Save frame** to save the currently captured frame to *JPG* file format on disk.

### 3.4.2 Window display modes (full screen, window, normal)

There is a variety of different window display modes available. Program starts in a **Normal** mode by default. You can select **Display mode** from context menu and then following options are available: **Normal** mode – default setting, program window covers all screen area, menu and all icons are visible, **Full screen** – only the cameras' views are visible (no icons and menu), **Preview** – works as the standard window you can drag-and-drop or scale, you can also turn on the option **Stay on top** that does not allow other windows to hide this program window. In **Full screen** and **Preview** modes you can also select the **Show menu** option to enable the menu display at the top of the screen.



### 3.4.3 Split screen modes (screen layout)

Using the icons to the left side of the window in **Normal** view you can change the split screen mode. Following modes are available: (2x2, 3+4, 2+8, 1+12, 1+7, 4x4).

### 3.4.4 Bookmarks

Particular frames could be bookmarked then the archives could be browsed by using special buttons. This option could save your time to find the event again in the archives. This can be used if you find the event interesting then you just right click the mouse button on camera view and select **Add bookmark** from context menu. Archives could be also bookmarked automatically by appropriate settings in **Scheduler**.

## 3.5 Configuration of camera settings

The system allows setting and saving numerous options for each of the cameras. To call up camera settings, select the menu item **Cameras**, submenu **Configuration menu** on the toolbar at the top of the screen, or press the  icon in the left hand icon bar. The camera settings window will be displayed. In the upper part of the window the icons of successive cameras are displayed, you can then click them in order to switch between settings for different cameras. The icon  means that the settings of this camera are currently displayed, while the icon  means that this camera is not present in the system, because there is no card to operate it (1 card has inputs for 4 cameras). The illustration below presents a system with one card, therefore cameras 5 to 16 are not active.

Below the camera selection bar, the screen is divided into 12 sections where the central section is occupied by the view from the selected camera.

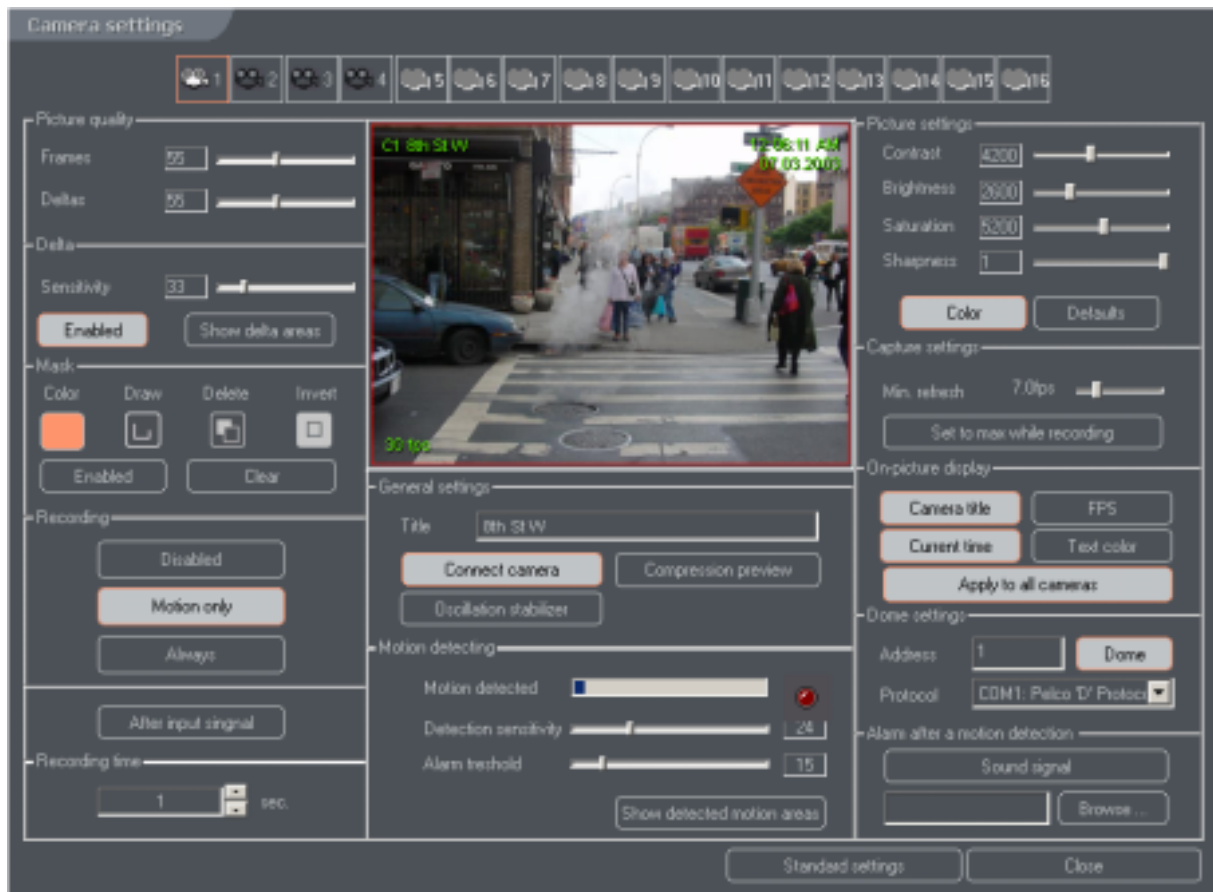

- **Picture quality** – determines the quality of archived images.

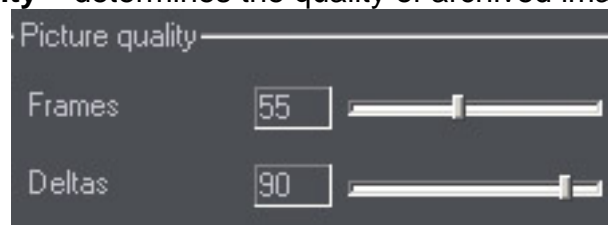

- **Frames** – quality of the key frame. Increasing this value increases the image quality but decreases compression. The key frame is used as a background for picture fragments – delta. In the **Program Settings** (Chapter 3.7) window you can set up the rate the key frame will be recorded. Default – 55.
- **Deltas** – determine the quality of the replaced part of the image, increasing this value increases the image quality but decreases compression. Default – 55.

- **Delta**

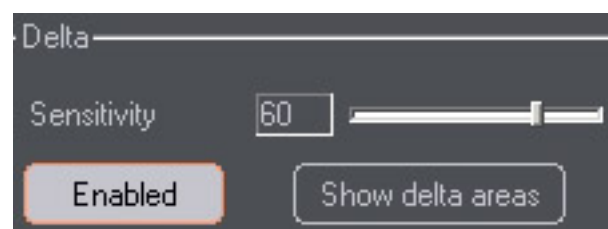

- **Sensitivity** – recommended setting for optimal quality: 63 – 65, for optimal record time set this up below 30. This parameter is used to scale the program response to the changes of the image. When the **Show delta areas** button is pressed, dots appear on the camera image, representing the replaced areas (deltas). Set this parameter in a way that the dots appear in a situation when actual motion is detected only. Not weather or effects of wind for example. **NOTE!** The sensitivity set too low may prevent replacement of deltas (areas in color similar to the background color will not be replaced – e.g. a person in a gray jacket walking on a gray street, or to small areas). On the other hand, the level set too high will cause unnecessary replacement of fragments where no motion has in fact been detected (e.g. caused by camera noise). Default – 22.
- **Enabled** button – turns on delta settings for the camera, switching this button off cause's full frames to be replaced.
- **Show delta areas** button – turns on display of deltas (in the form of red crosses), i.e. areas replaced by the program after detecting some motion.
- **Edit mask** – Putting a mask on the camera image allows determination of areas which should be excluded from motion detection. This may be used in a case where a fragment of the camera image contains a busy area out of your interest. An example may be a tree excepted from the observed image using a mask in order to ignore leaves moving in the wind.

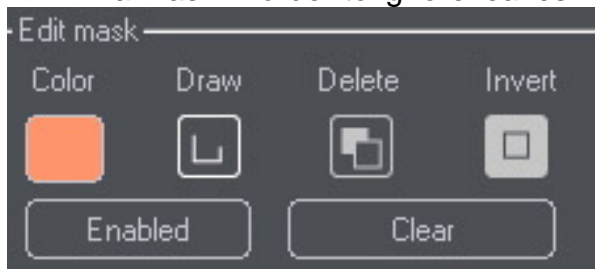

**Mask edit buttons**



**Mask setting example**

On the right side of the above illustration you can see an example of utilizing image masking. The system will not analyze motion in the areas covered by the mask (a busy street in this case).

- Click the first icon to change the mask color.
- Adding a masking area is possible after pressing the second icon, using the *drag-and-drop* method.
- Exclusion of a masking area, on the area which is already masked, is achieved by pressing the third icon; and moving the mouse pointer on the screen with the left mouse button pressed, as in the case above.



- The last icon inverts the mask selection, i.e. the areas that have been selected as the mask will be unselected, and the areas that have not been covered by the mask will be “masked”.
- **Enabled** button turns on the selected mask.
- **Clear** button immediately clears the mask from the whole image.



- **Recording**



- **Disabled** – Turns camera recording off.
- **Motion only** – only motion is recorded.
- **Always** – recording is turned on all the time.
- **After input signal** – recording is triggered after activation of selected alarm inputs only. After pressing this button a window will appear and it is possible to make a selection by marking the particular alarm inputs, to trigger recording. The image will be recorded for the period specified below in the **Recording time** option. This may be configured together with the **Motion only** option, recording will start after motion detection or alarm signal.



- **Recording time** – specifies the number of frames to be recorded by the program after the motion stops.

- **General settings**

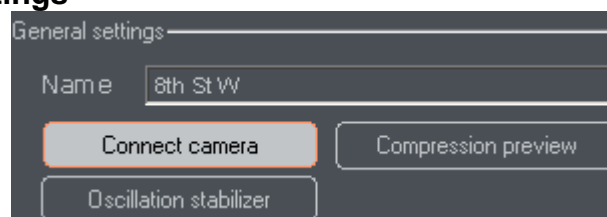

- **Connect camera** button – connects or disconnects the camera video signal source. Disconnecting a camera results in an increase in the frames per second rate for all remaining cameras connected to the same video capture card. Therefore, by disconnecting three of the four connected cameras you can achieve a real-time image from the remaining connected camera. When all the cameras are connected, the frame rate is shared. The capture speed is also dependent on the processor speed. For example, with a **Pentium 4** 1.8 GHz processor this is 4 ~ 6 frames per second for one camera (with all sources

connected and 4 cards in the computer). In high motion area, the frame per second rate decreases due to high processor load.

- **Oscillation stabilizer** – this function stabilizes vertical oscillations of the camera.
- **Compression preview** button turns on the preview of quality of the recorded image. When it is activated, no additional information (number of frames, time, and camera name) is displayed in the preview window. It is not recommended to leave this option activated because you will see the image in compressed form.
- **Camera Name** - use this field to set up the camera name.
- **Motion detection sensitivity**

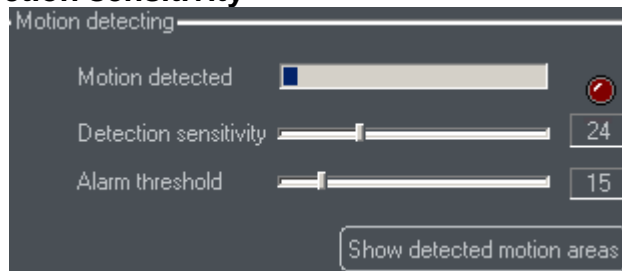

- **Show detected motion areas** button – toggles on/off marking with dots the areas where motion has been detected. It is not recommended to leave this option activated because it decreases the system efficiency. It should only be used during configuration of the motion detection sensitivity settings.
- **Detection sensitivity** – used to set the detection threshold for a single block. The block is an 8x8 pixel rectangle. The program analyses the current information about changes in a particular block, and you can use this slide to determine the sensitivity. Where the motion level is determined by this slide is exceeded dots are displayed.



- **Alarm threshold** – it is used to determine, when the system is to respond to the changes of the observed image. The **Motion detected**

sensor placed above allows adjustment of the **Alarm threshold** setting. The threshold should be adjusted when the image is still. The purpose of this option is to eliminate recording of noises such as leaves in the wind. It is necessary to press the **Show motion detection areas** button on the required frame. This will allow observation of dots appearing on the camera image preview. The dots represent motion exceeding the detection sensitivity level, detected by the program, and the number of dots displayed on the camera image decides about the level of deflection of the **Motion detected** sensor.

- **Picture settings** – standard parameters determining basic properties of the displayed image (contrast, brightness, saturation, sharpness).

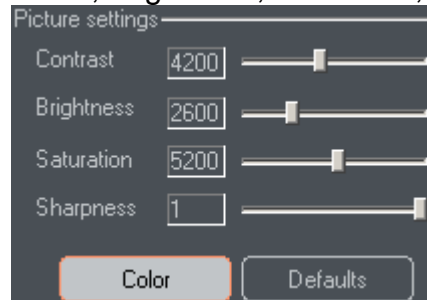

- **Color** button – switches between color and grayscale image. If the connected camera is black and white, deactivate this button.
  - **Defaults** button – restores default settings of the slides in this frame **only**.
- **Capture settings**

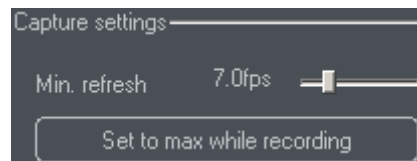

- **Set to max while recording** – if the option has enabled the system it will try to allocate the available captured frames to this camera if the motion is detected by this camera. In other words the system is doing the relocation of available captured frames from other cameras to this one but only if other cameras do not detect the motion. Besides captured frames cannot be relocated from the camera below its minimum refresh rate.
  - **Min. refresh** – you can set minimum guaranteed frame per second rate for this camera. System cannot relocate captured frames for this camera below the settings.
- **On-picture display** – allows selection of displaying additional information on the camera images.

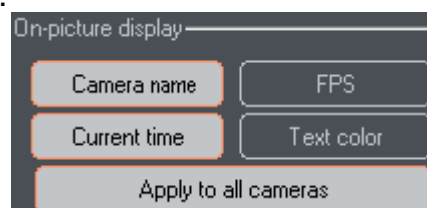

- **Camera name** button – displays camera name on the image.
- **Frames per second** button – displays current number of frames captured per second.
- **Current time** button – displays current time and date.
- **Text color** button – changes the color of texts displayed on the screen.
- **Apply to all cameras** button – if it is selected, then the color of text displayed on the image is changed for all the cameras, if not, then it is changed for the currently connected camera only.
- **Camera settings** – In the program versions which operate domes (not in the Home Edition) you can specify **Dome addresses** and press the **Dome** button, notifying the program that a video camera with a dome is connected to the video input. You have to select appropriate protocol for the dome. Of course, the protocol must be assigned to the serial port (COM) in the **Dome settings** window (Chapter 5.1), before you can use these settings here.

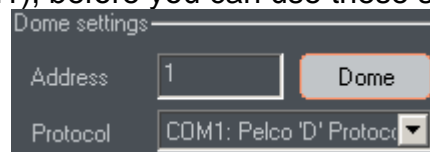

- **Alarm after motion detection** – determines the system behavior in the event of motion detection on the observed image.

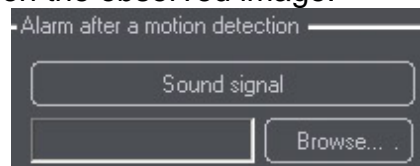

- **Sound signal** – the system generates an audible signal, which you can configure by selection of a sound file. The sound will be generated after motion detection if configured in the scheduler of camera operation.
- **Standard settings** - button at the bottom of the window restores default settings in the whole window (except for the **Parameters** frame).
- **Close** - button confirms the introduced changes.

### 3.6 Configuration of the video capture card

You can start configuring the video image capture cards by clicking the  icon in the icon bar on the left side of the main screen, or selecting the **Video cards** submenu from the **Configuration** menu on the top toolbar.

In the upper part of this dialog window there is a list of icons representing the video cards installed on the system. Below there are four blocks containing individual options of settings for the video capture cards. Click on an icon representing a particular card in order to display the current settings for that card. Settings can then be customized as necessary.

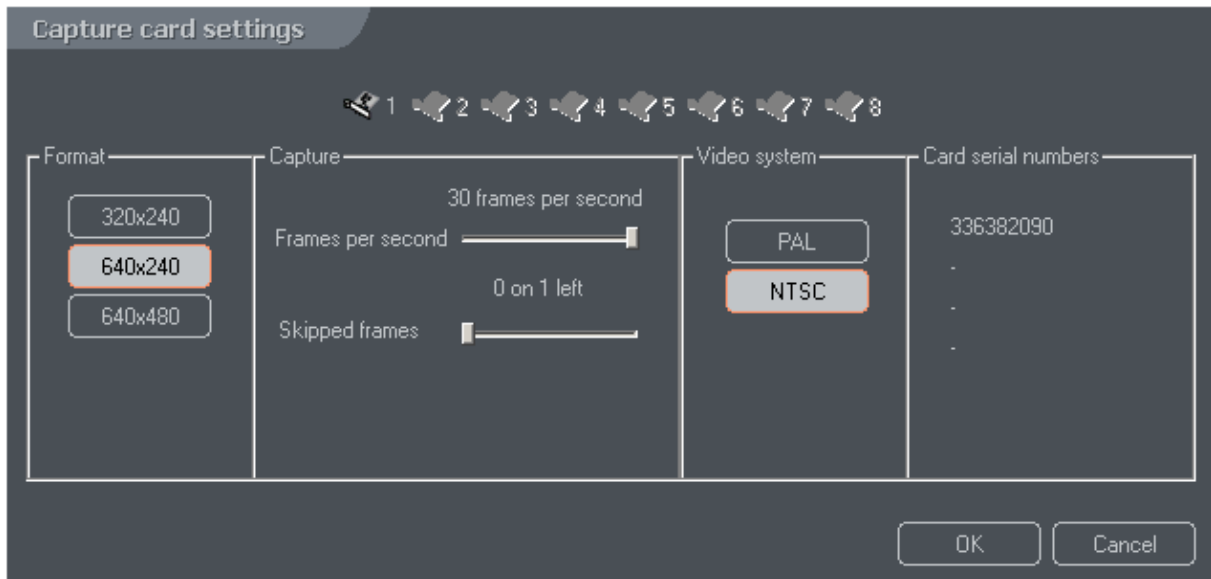

- **Format** – determine the size of the captured frames. Depending on the selected television system (**PAL**, **NTSC**), you can select the size using one of the three buttons:

<b>Selected TV system</b>	<b>PAL</b>	<b>NTSC</b>
<b>Button 1</b>	384x288	320x240
<b>Button 2</b>	768x288	640x240
<b>Button 3</b>	768x576	640x480

The TV system selection is made in the **Video system** block described below.

- **Skipped frames** – determine the number of skipped frames. Low-resolution cameras may generate unstable images, so in order to achieve better synchronization you can use frame skipping. The recommended setting is **1 on 1 left**. Increasing this value results in an increased processor load. This option may also be used to save hard disk space, but note that the number of captured frames will decrease. The range of frames to be skipped: from 0 to 5. If the processor cannot handle this load (the number of captured frames is very small), it is necessary to increase the number of skipped frames to **2 on 1**. This option is configured for each of the cards separately. In order to apply these settings you must restart the program.
- **Video system** – allows selection of the television system for the captured image. The buttons **PAL** and **NTSC**, specifying the selected system format, cause change of the size of captured images.
- **Card serial number** – numbers of the video cards installed in the system. This is used for checking the authenticity of the cards.

Press the **OK** button at the bottom of the window in order to confirm the entered changes. The new settings will apply after the VideoDR-S system is restarted.

### 3.7 Configuration of program settings

In order to configure the program settings, press the  icon in the icon bar on the left side of the application screen.

- **E-mail server settings (SMTP server)** – these settings are required, if you use the notification option. In the **Server address** field enter the name of the mail

server, from which the email messages will be sent, and the port number if necessary (default port value is 25). In the **Sender address** field enter the name of the email message sender.

- **Event diary** – in the **Folder** field you can select the folder, in which the system log file will be kept (for events, alarms, etc.). The **Max. size of an event diary** field specifies, how much space may occupy the log file.
- **Language** – selection of the interface language. After a change you need to restart the VideoDR-S application.
- **Recording** – Options allows you to adjust the rate the key frame is recorded. In other words the option means that, the entire frame is recorded every XX delta frames, where XX – is adjusted number.
- **Use DirectX** – if your graphic video board supports DirectX hardware acceleration then you can enable this option. It will result in better performance and better picture quality.

**Program settings**

E-mail server settings (SMTP server)

Server address: mail.servername.com Port: 25

Sender address: videodrs@mail.servername.com

Event diary

Folder: C:\VideoDR-S.logs Browse

Max. size of an event diary ( MB ): 10

Language: ENGLISH

Recording: Key frame every 100 frames

Use DirectX

OK Cancel

### 3.8 Configuration of Network Settings – video server

Go to the network settings; press the  icon in the icon bar on the left side of the application screen.

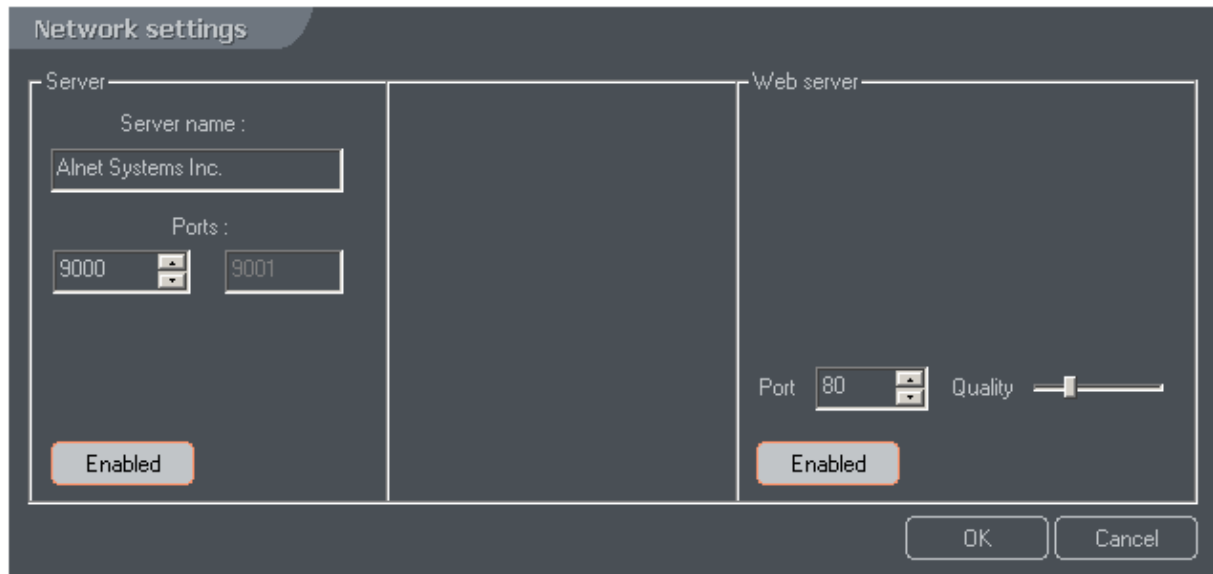

In the new window you can select the following options:

- **Server**
  - **Server name** e.g. *Company* name as seen by the client application.
  - **Ports**, on which the server will operate, e.g. 5555 (by default 9000).
  - The button is used to switch the server on or off.
- **Web server**
  - **Port** - on which the server will operate,
  - **Quality** – the quality of the pictures sent to remote client,
  - The button is used to switch the web server on or off.

### 3.9 Configuration of archive files

A critical part of the VideoDR-S system configuration is to specify a physical data location, i.e. hard disk space where the program will save the video image archives. The file size settings are available after pressing the  icon in the icon bar on the left side of the main application screen.



- **Archive files location** – Specifies the location of the saved video images. Double-click the number in the **Size** or **File size** column in order to edit this field. You can specify the maximum size of the archive in this location. The **File size** specifies the size of files in this folder, and after you press the **Rebuild archive files** button, the program will create as many files as necessary to fill the location, up to the selected **Size**. When all space is used, the oldest recordings are over-written, therefore allowing infinite recording. **NOTE!!!** If you check the **Fast formatting option** then the recommended **File size** is 100MB. Fast formatting option just creates the files and before the system starts recording the file must be formatted. So if this is 100MB file it takes about 3 seconds to format this and during the format operation there will not be any recording. If you do not want to stop the recording for those moments you have to uncheck the option then the approximate time of formatting 80GB video base is about 2 hours.
- **Add a new location** – you can create a new location for the files.
- **Delete selected location** – removes the selected location for the files.
- **Change path** – allows selection of another path for the archive.
- **Rebuild archive files** – it is necessary to rebuild the archive files after every setting change. Press this button to rebuild the archive bases according to the selected options, and for the changes to take effect.

### 3.10 Configuration of server access accounts

Open the access configuration window by clicking the  icon in the icon bar on the left side of the main application view. The window below is used to configure access to the VideoDR-S system. It allows creation of accounts for users with different *access rights*. In the upper part of the window a list of user accounts is displayed, below there are the **Add user**, **Edit user**, and **Delete user** buttons.

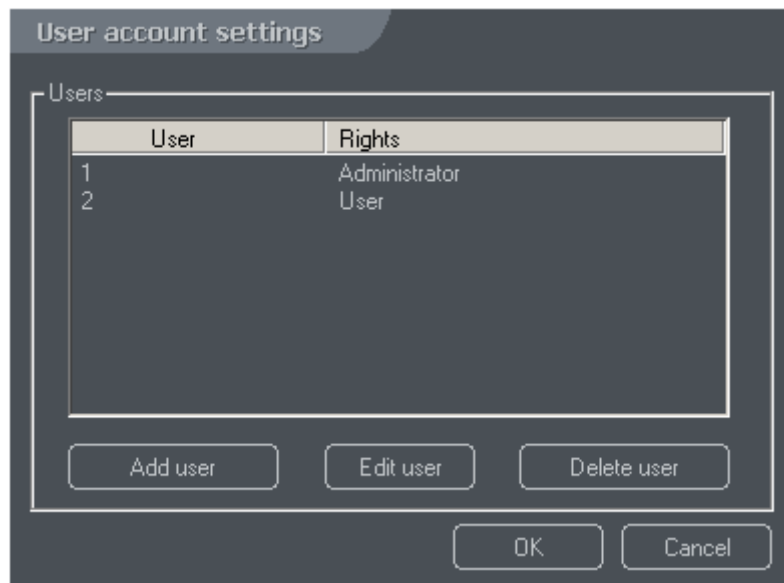

### 3.10.1 Editing an account

When you select an account from the list and press the **Edit user** button, a new window will be displayed where you can freely change User details and rights. The **OK** button confirms changes.

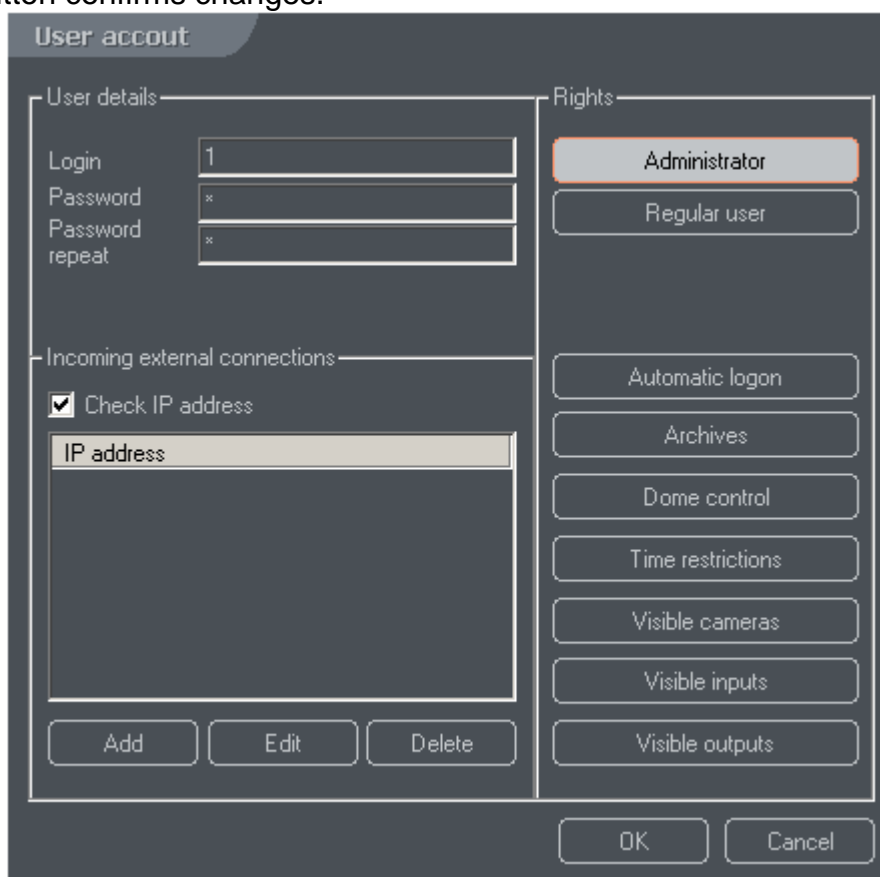

In the **User details** panel you can change the User password.

In the **Incoming external connections** panel you can specify unique IP addresses of the Internet network the user can remotely log into the system from, using the

**client** application (VideoDR-C). This additional security feature prevents access from unauthorized computers.

In the **Rights** panel you can specify the rights granted to the user. If the **Administrator** button is pressed, the user has the administrator rights, and will have full administrative control of the VideoDR-S program. In addition, the **Automatic logon** button will be available. Pressing this button will automatically log this user into the system after program startup, skipping password authentication. This option relates only to **the first** administrator account created in the system. Pressing the **Regular user** button assigns no access rights to change the settings by default, only logon rights and select view or access to archives. Individual rights are set by clicking the following buttons: **Archives**, **Dome control**, **Time restrictions**, **Visible cameras**, **Visible inputs**, **Visible outputs**. Each time you press any of the listed buttons, a window appears, where you can grant or deny access by selecting the desired options with the mouse:

- **Archives**



Click the camera icons in order to specify, to which camera recordings the user will have access. The cameras accessible to the user are highlighted in white with an orange border. The user should always have access to at least one camera, to avoid a situation where only empty frames are visible in the client application.

- **Dome control**



Click the camera icons in order to specify, which camera dome control the user will have access to. The domes that can be controlled by the user are highlighted with an orange border.

- **Time restrictions**

The window is divided into three columns. The first column specifies whether the user will have access to the application on a particular day of the week, the next column specifies times of the day access are available to this user.

In order to activate user logging into the system on a given day of the week, press the corresponding button, which will become highlighted. All the changes are then confirmed with the **OK** button.

- **Visible cameras**

Click the camera icons in order to specify, which cameras the user will have access to. The cameras accessible to the user are highlighted, a white camera with an orange border.

- **Visible inputs**

Click the appropriate alarm input icon in order to specify which alarm input settings the user will have access to. The inputs accessible to the user are highlighted in orange with an orange border.



- **Visible outputs**

Click the appropriate switch output icon in order to specify switch settings the user will have access to. The switches available to the user are highlighted in red and the handle is pointed downwards.

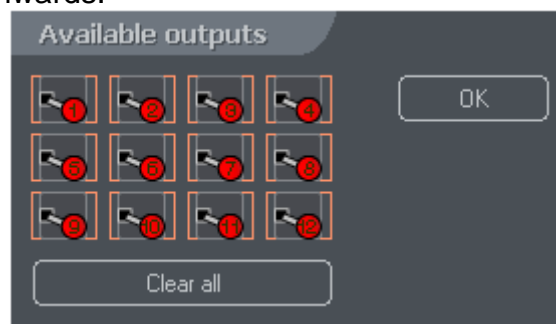

### 3.10.2 Adding a new account

To add a new user, press the **Add user** button and edit the account settings in the newly opened window. Editing the new user details is similar to editing an existing user, described in the previous section.

### 3.10.3 Deleting an account

To delete an account, select it and press the **Delete user** button.

## 3.11 Configuring DNS service

Dynamic Domain Name Service (D.N.S.) - the VDRS does not require you to have a static IP address (which can add to the cost of your internet connection). If your ISP offers dynamic IPs only, you can register for free your own subdomain, by entering your desired server name in the DNS registration box. Every time you start up your server, it will automatically register/update its dynamic IP address with our vdr-s.com domain name server. This will enable your clients to access your server at any time by simply entering your servername.vdr-s.com in the address box. Regardless of any change to your assigned IP address. This process only involves your initial input the first time you register your dynamic IP with us. The rest is done automatically by Alnet VDRS and our dedicated VDR-S.com server.

To register your subdomain, select **Tools** from main menu and then select **Register domain**. You can also do it going to **Start** menu, **Programs**, **AL-NET**, **Register**

**Dynamic D.N.S.** It will open new registering window where you can enter all required parameters:

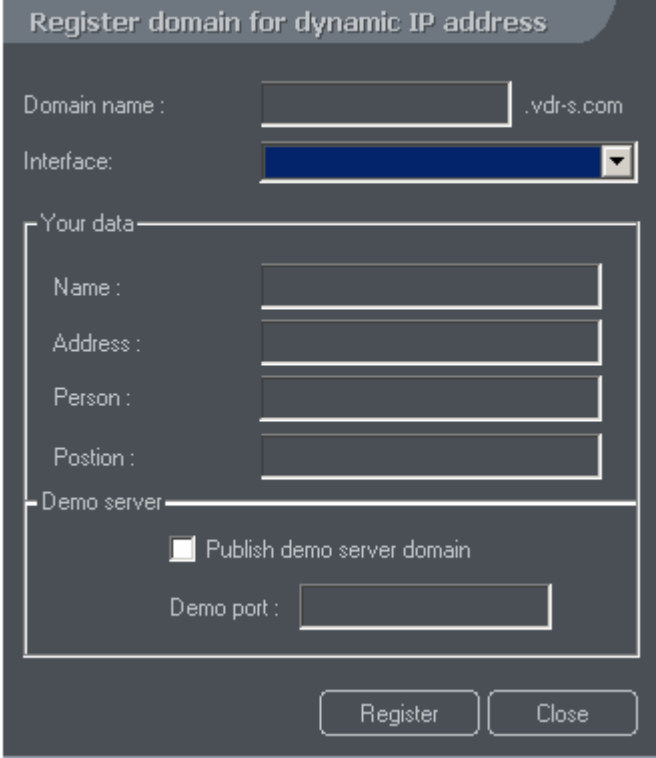

Register domain for dynamic IP address

Domain name :  .vdr-s.com

Interface:

Your data

Name :

Address :

Person :

Position :

Demo server

Publish demo server domain

Demo port :

Register Close

You have to fill out this form and following fields:

**Domain name** – enter the subdomain you would like to have.

**Interface** – select the network adapter that is connected to Internet (there could be more than one network adapter so you will have to select the right one)

**Name** – name of the company that is registering the subdomain

**Address** – address of the company

**Person** – person responsible for this system in the company

**Position** – what is the position in the company of this person

If you agree to let people to have access to your server for demo purposes you can select the **Publish demo server domain** in the **Demo server** frame. This demo server will be published on our website. You are also required to create user **demo** with password **demo**. Please, enter also the port on which the server works in **Demo port** field.

To start using this service fill out the form and click **Register** button. If you have **unauthorized access** error as a return message, contact us.

## 4 Using the VideoDR-S system

### 4.1 Browsing the video image archive

To go to the archive view, press the  icon in the icon bar on the left side of the main view of the VideoDR-S system, or select the **Archive** submenu from the **Tools menu** on the toolbar at the top of the screen.

The archive view called up then replaces the main view.



The upper part of the archive window displays a time chart of the recordings; the **log**. The green bars represent recorded camera images. Use the mouse pointer to select a particular position in the log, to display the image recorded at that moment.

The camera image currently selected with the mouse pointer is marked with a red border.

The bar of the currently selected camera is highlighted. In the upper left corner, below the time log, there is an indicator of the time corresponding to the current position of the cursor in the time log.

The yellow vertical bars indicate the time when the system was switched on or off.

**NOTE!** The video archive of the server may also be browsed remotely using the client type application (**VideoDR-C**).

### 4.1.1 Control panel of the archive

On the left side of the screen there is a control panel of the archive:

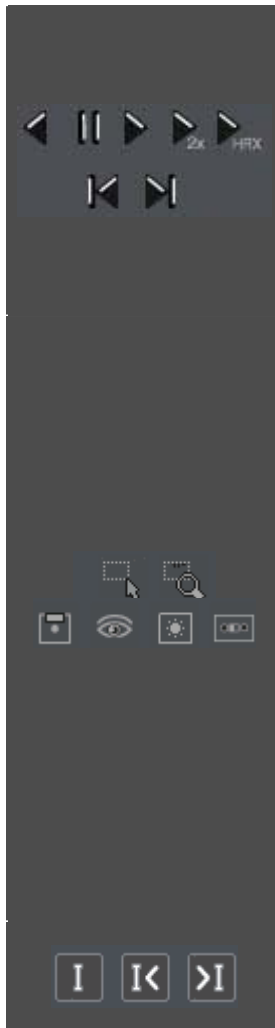

The following is a description of the image control playback buttons.

The icon plays the recording in real-time forward. The **2x** icon plays at twice real-time speed. The **MAX** icon plays the recording at the maximum speed possible considering the processor ability.

The icon stops playback. The icon plays the recording at real-time speed in reverse. The and icons allows playing one frame forward and backward respectively.

The icon allows selection of the motion searching areas on one or more cameras. The icon starts the motion detection process in the previously selected fragment of the image. Detailed description is available in Chapter 4.1.2.











The icon allows you to zoom in on the image from the archive.

Selecting the icon allows saving a frame from the currently selected camera. The currently selected camera is indicated by a red border.

The icon displays a window with options for correction of the played image for individual windows. You can also specify the sensitivity of motion searching in the archive.

The icon allows recording selected camera specified period of record time as the AVI file. You can select any code installed on your computer.

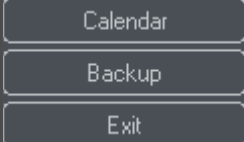
Those icons are used as following: 1<sup>st</sup> – to insert a bookmark where the cursor is set, 2<sup>nd</sup> – to browse bookmarks backward, 3<sup>rd</sup> – to browse bookmarks forward.

	<p>The first field displays the time from the video archive, corresponding to the position of the mouse pointer.</p> <p>The second field displays the time at the beginning of the chart, displayed at the top. The third field displays the time at the end of the chart.</p> <p>The buttons below are used to move the zoom in and zoom out of the images of time charts of the recordings.</p> <p>The   icons move the time chart forward, the first one by several frames, the second by the whole range (setting the end of the chart at the beginning, keeping the scale).</p> <p>After you zoom the camera image to the whole screen, the  and  icons move the image forward and backward respectively, at one second steps.</p> <p>The  icons move the time chart backward, similar to the icons moving the chart forward.</p> <p>The  icon scales the time chart by zooming in, while the  icon scales the chart by zooming out.</p> <p>The  icon scales the image to the whole selected day from 00:00 hours to 00:00 hours of the next day.</p> <p><b>NOTE!</b> Zooming into the time charts is also possible using the mouse: place the mouse pointer on the time chart, click and hold the left mouse button, moving the mouse pointer to the end of the desired fragment, then release the mouse button (just as you select text in a text editor).</p>
	<p>The <b>Calendar</b> button allows selection of the archive from a particular day and displays it in the form of a time chart.</p> <p>The <b>Backup</b> button displays a dialog window for creating a backup copy of the video archive from a selected time period.</p> <p>The <b>Exit</b> button closes the archive window.</p>
	<p><b>Image division.</b> These icons divide the screen into frames in the layout indicated by the icons, similar to the main view of the VideoDR-S system.</p> <p>If you right-click a camera image, a window will appear allowing selection of the particular camera.</p> <p>You can freely change the sequence of camera images, using the drag-and-drop method, i.e. left-clicking an image to place them in a particular order.</p>

### 4.1.2 Searching for motion in image archives

The VideoDR-S system allows motion searching in the video archives. This function is useful if you want to see, what has caused motion in a particular area, but you do not want to browse through the archive frame by frame. To do this, press the icon to select the motion searching areas. The program will enter the mode of selecting areas for motion detection. Select an area on the image from one camera or several cameras, using the mouse cursor. Next press the  icon to begin the process of motion searching in the archive. The VideoDR-S system will rewind the archive to the point where a motion was detected in any of the selected areas. The

video playback will be stopped and you will hear sound signal (where available). Click the  icon again in order to continue motion searching. Below you can see an example of motion searching in the selected areas:



You can specify the motion searching sensitivity in the archive for each of the cameras separately. This option is available in the image parameters window, called up by the  icon.

### 4.1.3 Exporting archive to AVI file

You can export any part of the recorded video as AVI file (a computer movie-like format). Any of the installed codes may be used (DIV-X, MPEG-2, MPEG-4).

Export video sequence to AVI file

Camera name : C1 Camera 2

Time span :

12:00:00 AM / 22.02.2003 11:59:59 PM / 22.02.2003

Frames per second in AVI file : 10

File name :  Browse ...



OK Cancel

First, select the camera to export video from, time span, fps rate and the file name. After clicking **OK** button you have to select the codec to encode the file.

#### 4.1.4 Inserting the bookmark into the video archive

Using the bookmarks you can quickly browse the archive to the previous set up positions. Inserting the bookmark is possible while watching live picture as well as browsing the archive by clicking right mouse button on picture and selecting **add bookmark** from the context menu. You can add the bookmark by clicking the icon in Archive view mode, set up marking the video if motion detection happens or if alarm input is activated or if any other event support by schedule happens. The bookmark is presented as vertical red bar in the archive time log. Browsing the bookmarks is easy by using the special bookmark buttons in the Archive view as described in Chapter 4.1.1.

#### 4.1.5 Zooming into fragments of the image

The  icon is used to enter the mode of selecting areas for zooming in. In this mode selecting a fragment of the image (i.e. dragging the mouse cursor with the left mouse button held and releasing the button at the end of selection) causes the selected fragment to be enlarged to the whole window of image display. To exit the zooming mode, enter the mode of selecting areas for detection (the  icon), or press the zooming icon again. You can play the zoomed image, and you can set a different zooming area for each camera.

### 4.1.6 Setting the archive image parameters and motion detection sensitivity

While the video image is being viewed, you can adjust its parameters in real-time. Those parameters are adjusted for each of the cameras separately. The window is called up by the  icon.



The **Detection sensitivity** parameter relates to the sensitivity of motion search in a given archive for a specified camera. Move the indicator to the right in order to increase the sensitivity.

Slide bar settings: **Sharpness**, **Brightness**, **Contrast**, **Saturation** are used to adjust the played image depending on the position of the indicator. Move the indicator to the left to decrease the value and to the right to increase the value.

### 4.1.7 Scaling the time charts

The  icon scales the time chart by zooming into it (making it appear closer), while the  icon scales the chart by zooming out of it (making it appear farther).

Pressing the **Show a whole day** button scales the log in so that the beginning will be set to 00:00 hours on a given day and the end will be set to 00:00 hours on the following day.

Zooming into the time charts is also possible using the mouse: place the mouse pointer on the time chart, left-click and hold the mouse button, moving the pointer to the end of the desired fragment. Release the mouse button (just as you select text in a text editor). This will result in zooming into the selected fragment so that the selected beginning will become the beginning of the chart, and the selected end will become the end of the displayed chart.

### 4.1.8 Browsing recordings from a given day – using the calendar

The VideoDR-S system allows browsing the archives using a handy calendar. It is called up by clicking the **Calendar** button in the archive control panel. A calendar window will be displayed, dates in bold indicate recordings made on that day. To view the archives select the date and click OK.



## 4.2 Scheduler

The VideoDR-S system allows creating a schedule for camera operation. Depending on the occurrence of an event connected with a particular camera, an input or the system at a particular moment in time, you can program a desired system response.

The scheduler window is called up by clicking the  icon in the icon bar on the left side of the main view, or selecting the **Scheduler** submenu from the **Tools** Toolbar at the top of the screen. You can access a desired schedule (for cameras, alarm inputs, system alerts) using the tabs in the upper part of the window.

### 4.2.1 Camera Operation Schedule (motion detection alarm)

You can define a whole list of tasks for one or more cameras during different periods of time. Each of those tasks is executed independently of the other tasks. When defining a task, you can specify, when the motion detection should cause the predefined response. In the upper part of the window there is a list of defined tasks. Initially there are no tasks listed. Added tasks will appear in this list. In order to edit a task, select it on the list, modify the desired parameters and press the **Change** button. In order to add a new task to the list, set the parameters accordingly and press the **Add** button. In order to remove a task, select it on the list and press the **Remove** button.

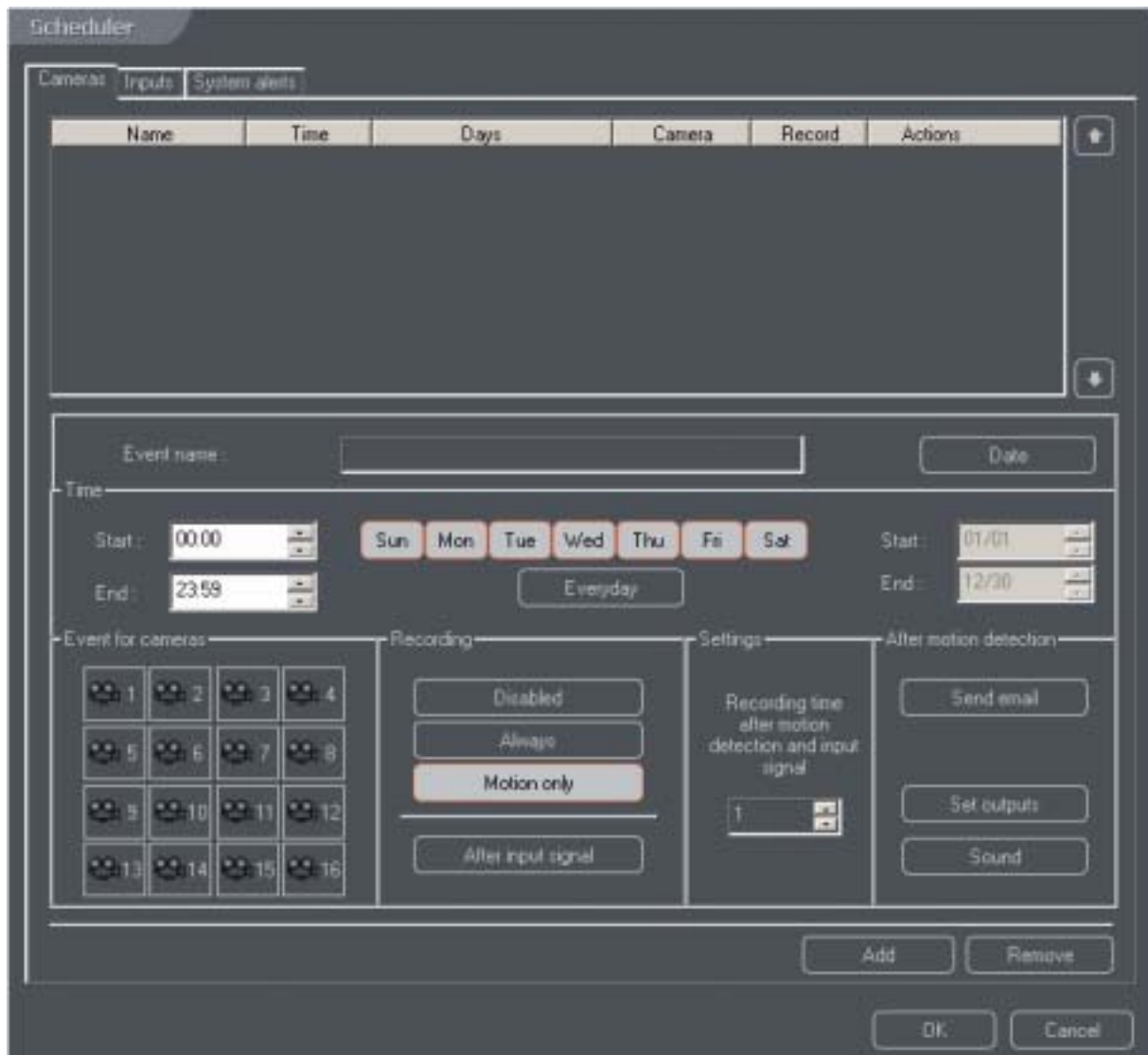

**Event name** – the name of the programmed task (e.g. night guard).

**Date** – pressing this button activates the options below (**Start:**, **End:**), where you can specify time parameters for the task to be executed.

**Time** – specify the days of week and the time of day when the task should be executed. The **Everyday** button selects all the days of week.

**Event for cameras** – select the cameras, for which the motion detection should activate the task.

**Recording** – one of the three recording options is possible: **Disabled**, **Always** or **Motion only**. The selected option will be carried out after activation of the motion detection event. The **After input signal** option allows the task to be activated also after detection of the alarm state at an input.

**Settings** – you can specify (in seconds) the time of recording following detection of the event.

**After motion detection** – notification selection about the alarm event in the period of duration of the task. You can program the system to notify you about this via an email message (**Send email**) to specified addresses, with images from the selected cameras attached (clicking displays a window with a list of email addresses and an address book – see Chapter 4.3), sending an SMS message (**Send SMS**), switching

on selected outputs (**Set outputs**) (e.g. an alarm buzzer connected to the relay output, or a buzzer in the guard room), or generating a **sound** previously assigned to a particular camera in the camera settings, using speakers connected to the computer.

#### 4.2.2 Input Operation Schedule

You can define a whole list of tasks for one or more alarm inputs at different times. Each task is executed independently. When defining a task, you can specify conditions that cause a programmed response. In the upper part of the window there is a list of defined tasks. Initially there are no tasks listed. When a task is added it will appear in this list. To edit a task, simply select it from the list, modify the desired parameters and press the **Change** button (the **Add** button changes to the **Change** button). In order to add a new task to the list, set the parameters accordingly and press the **Add** button. In order to remove a task, select it on the list and press the **Remove** button.

The screenshot shows the 'Scheduler' window with three tabs: 'Cameras', 'Inputs', and 'System alerts'. The 'Inputs' tab is active. At the top, there is a table with columns: Name, Time, Days, Inputs, and Actions. Below the table is a form for defining a task. The form includes:
 

- Event name:** A text input field.
- Date:** A date selection button.
- Time:**
  - Start:** A time selection field set to 00:00.
  - End:** A time selection field set to 23:59.
  - Days:** A row of buttons for Sun, Mon, Tue, Wed, Thu, Fri, and Sat. A button labeled 'Everyday' is also present.
  - Start Date:** A date selection field set to 01/01.
  - End Date:** A date selection field set to 12/30.
- Event for inputs:** A 4x4 grid of camera icons numbered 1 through 16.
- After input activation:** A set of buttons including 'Send email', 'Add bookmark', 'Set outputs', and 'Sound'.

 At the bottom of the form are 'Add' and 'Remove' buttons. At the very bottom of the window are 'OK' and 'Cancel' buttons.

**Event name** – the name of the programmed task (e.g. night guard).

**Date** – this button activates the options below (**Start: End:**), where you can specify time parameters for the task to be executed.

**Time** – specify the days of week and the time of day when the task should be executed. The **Everyday** button selects all the days of week.

**Event for inputs** – select the inputs for which the alarm state should activate the task.

**After input activation** – select a form of notification about the alarm event in the period of duration of the task. You can program the system to notify you by sending an email message (**Send email**) to specified addresses, with attached images from the selected cameras (clicking displays a window with a list of email addresses and an address book – see Chapter 4.3), switching on selected outputs (**Set outputs**) (e.g. an alarm buzzer connected to the relay output, or a buzzer in the guard room), marking the time chart with a bookmark (**Add bookmark**) or generating a (**Sound**) previously assigned to a particular camera in the **Camera settings** (Chapter 3.5), using speakers connected to the computer.

### 4.2.3 System alerts

You can define which events should trigger sending an email message or an SMS message.

The screenshot shows the 'Scheduler' window with the 'System alerts' tab selected. The interface includes a table for scheduling tasks and a configuration panel for system alerts.

Name	Time	Days	Actions

Event name:  Use date

Time

Start: 00:00    Sun Mon Tue Wed Thu Fri Sat    Start: 01/01

End: 23:59    Everyday    End: 12/30

System alerts

- Program start up
- Program shut down
- Recording on
- Recording off
- Camera connected
- Camera disconnected
- Remote user login

Notifications

Send email's

Send SMS

Add Remove

OK Cancel

In the upper part of the window there is a list of defined tasks. Initially there are no tasks listed. Tasks added will appear in this list. In order to edit a task, select it from this list, modify the desired parameters and press the **Change** button (the **Add** button changes its name to the **Change** button). In order to add a new task to the list, set the parameters accordingly and press the **Add** button. In order to remove a task, select it on the list and press the **Remove** button.

**System alerts** – each time the selected event occurs in the system, the action selected in the **Notifications** will be executed – i.e. sending an email message with fixed contents. Clicking the **Send email** button displays a window with a list of email addresses and the address book – see Chapter 4.3.

### 4.3 Selecting and adding new email addresses

The program allows sending information together with attached images from selected cameras by electronic means. It is possible to define a whole list of email addresses and to select them from the address book. Selecting **Send email** option in a camera operation schedule, input operation schedule or system alerts, will cause a window to be displayed with a list of email addresses notification is to be sent to. If you want to assign an address to a specific event, mark it on the left side by the address. In the **Address book** tab you can define different addresses and add them to the list of addresses notification is to be sent to.

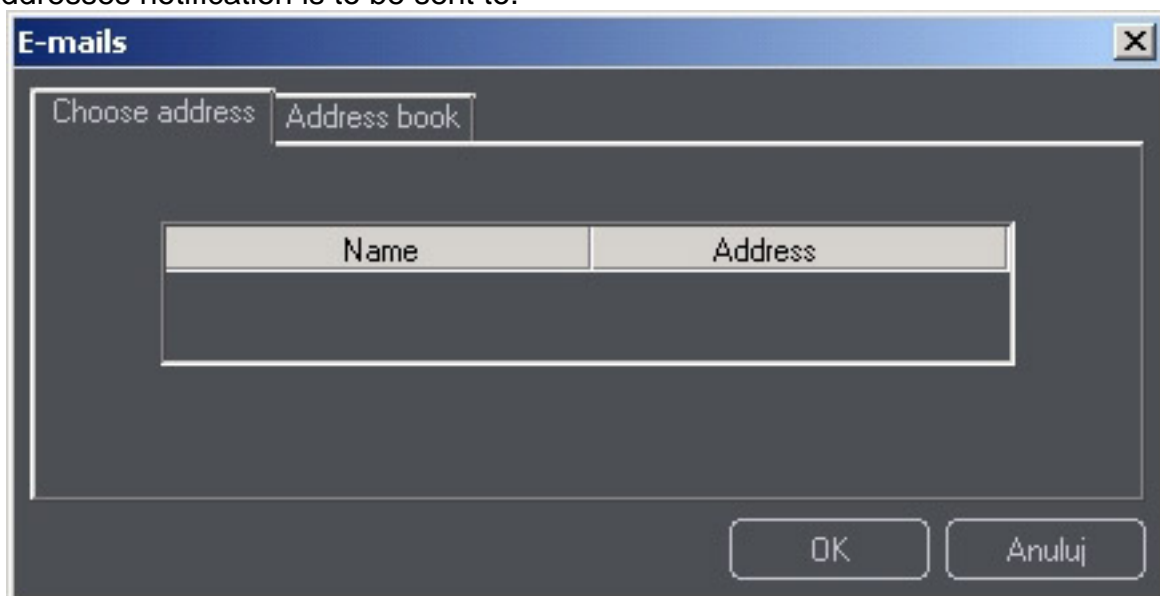

**Address book** - enter new and edit existing addresses

**Description** – this is a meaningful name given to the email account.

**E-mail address** – electronic mail address.

**Subject** – subject of the email message to be sent.

**Do not send more often than** – time in seconds, specifying the frequency of sending an email during the period triggered by an alarm event.

**Attach screenshots** – select the cameras, to attach screenshots from.

**Get screenshots after** – a delay for capturing the images to be attached to the email.

Use the **Add new** button to insert an address with a configuration of frequency and camera images. Use **Remove** button to remove the selected address, **Change** button allows address editing.

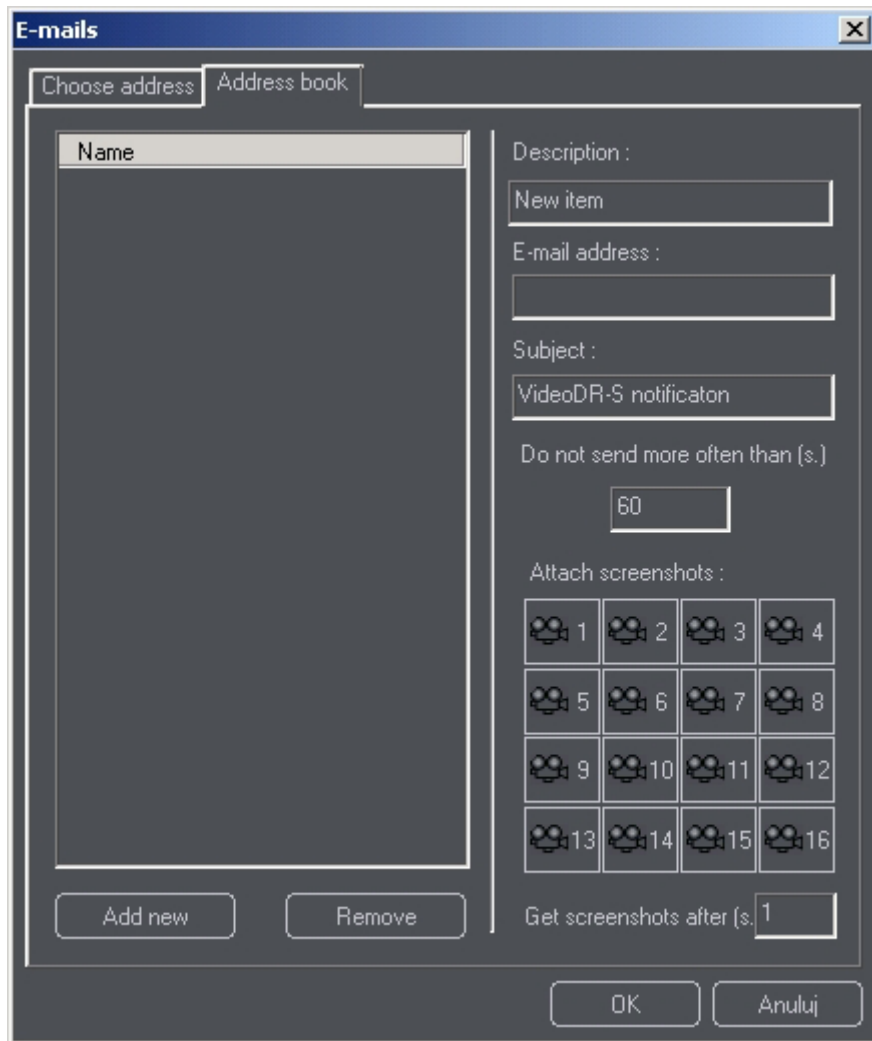

Sending SMS messages to mobile phones/PDA will work in a similar manner (SMS features depends on your local cellular phone company).

#### **4.4 Creating a backup copy of the video image archive**

To create a backup copy of the archive, select the **Backup** submenu from the upper **Tools** menu. A new window will be displayed, and you can configure the recording settings for the archives. This may take a while, because this option checks the database integrity, what is recorded on the disk, and at what location. The delay depends on the number of cameras and the time of recording.

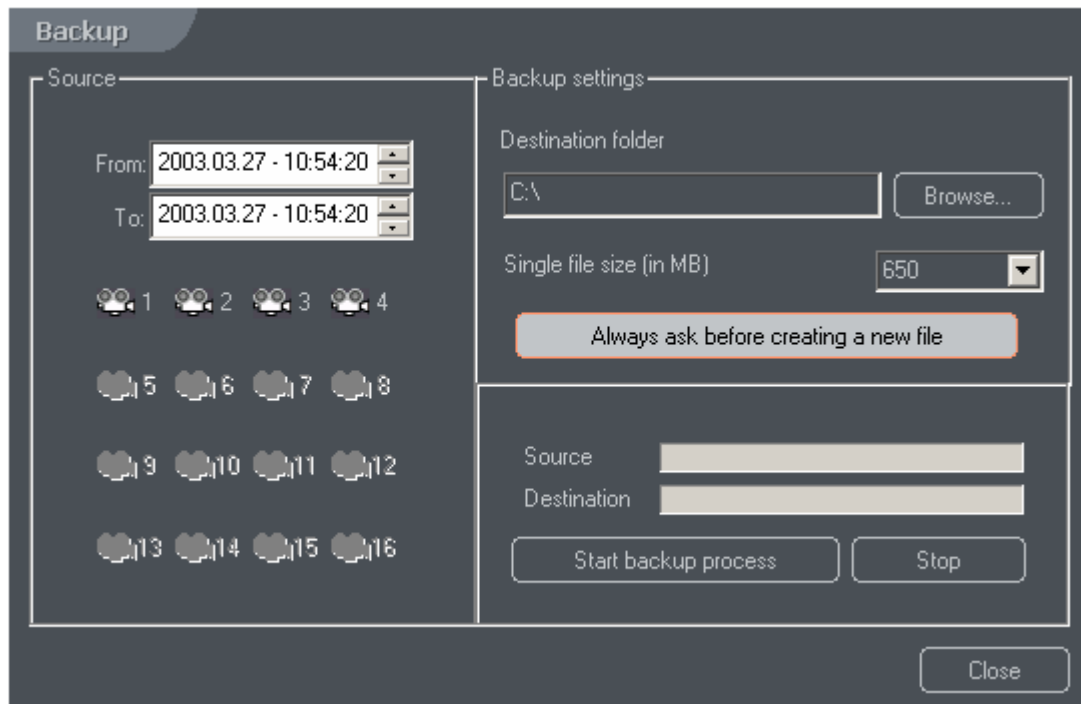

- **Backup settings** – in this window you specify:
  - **Destination folder** (it is possible to select an already existing folder on the disk, using the **Browse** button).
  - **Single file size (in MB)** – the size selected from the drop-down menu corresponds to popular capacities of CD-R and CD-RW disks. If it is exceeded, a sequential number is added to the name. You can also enter another value manually, e.g. 2000 MB.
  - **Always ask before creating a new file** – selecting this option will prompt for confirmation each time a new backup file is to be created.
- **Source** – specify the time period, for which the backup is to be created, and the cameras, from which the image is to be recorded.
- **Start & backup process** – executes archiving according to the configured settings. Depending on the processor speed, this may take a long time. It is recommended to create backup copies when traffic is minimal, or with the recording function turned off (when using slower processors).
- **Break** – stops the archiving process.
- **Close** – closes the backup window.

#### 4.5 Updating the program

There are two ways of updating the program:

1. Download the current version from the Internet page link located in the **About** window. There are two kinds of updates:
  - a. The first is a small file of several hundred kilobytes, named **VDR-S4PRO.EXE**, **VDR-S8PRO.EXE**, **VDR-S12PRO.EXE** or **VDR-S16PRO.EXE** (the digit determines the number of operated cameras),

that can replace older versions in the installation folder (default **C:\Program Files\VideoDR-S\VideoDR-S\VDR-S4PRO.EXE**)

- b. The second kind is a file of several megabytes: „**VideoDR-S4PRO\_update.exe**”, necessary for update if the previous version of the software being used is based on older drivers. If this method is used, you have to uninstall the old drivers first, using the **Device Manager**. Right-click on the **My Computer** icon, select the **Properties**, then the **Hardware** tag and the **Device Manager** button. A new window will appear, where you should expand the **Sound, video and game controllers** item and select the following drivers to be uninstalled: **ALNET VideoDR-S WDM Video/Audio Capture**. Once the uninstallation process is completed, the VideoDR-S System update application can be executed. Then you can start the application that updates the VideoDR-S system.
2. Use the **Program update** function available in the menu of the VideoDR-S program. This function is described below. **NOTE! This function is not implemented in the current version of the program.**

You can update the program, selecting the **Program update** submenu from the **Tools** toolbar menu at the top of the screen.

**NOTE!** To use this method, an internet connection is required.

Press the **Download information about updates** button. The program will connect to the update server and download the information about current versions. In addition, the information about currently installed program components will be displayed.

Next, unselect the components that you do not wish to update and press the **Update the selected components** button. The program will indicate the download progress, and when completed the VideoDR-S system must be restarted.

#### **4.6 "About" window**

This window displays the information about the current version of the program and the address of the homepage containing program updates. The files to be downloaded will reside in the download folder. Information about the expiration of the program is displayed. If you have the unlimited time version the message "**No time limit dongle**" and the license number is displayed below the ALNET SYSTEMS logo.



#### **4.7 Exiting the program**

When you exit the program for the first time, you will be asked for the location and name for the server configuration file. In the future, each time you exit the program, this question is changed to the confirmation of saving of the new configuration. If the **No** button is pressed, all the changes in configuration, introduced since the last program execution will be lost.

#### **4.8 Login and logout options**

System provides you with the possibility of creating the user's accounts. In fact you could create the account for any person that might have the access to your computer. More information on managing the accounts you can find in Chapter 3.10. If for some reasons you have to leave the room where some people not authorized to use the server are you have two possibilities. Select menu **Program** then **Login**, the **Login** window appears and camera views disappear but system is still working, you can leave it as it is or login as less privileged user.

## 5 Dome control

**Note!** Dome control is only implemented in a Professional and Real-Time version of the VideoDR-S program. It is not implemented in Home Edition version.

### 5.1 Dome control settings

The dome control settings window is called up by clicking the  icon in the icon bar on the left hand side.

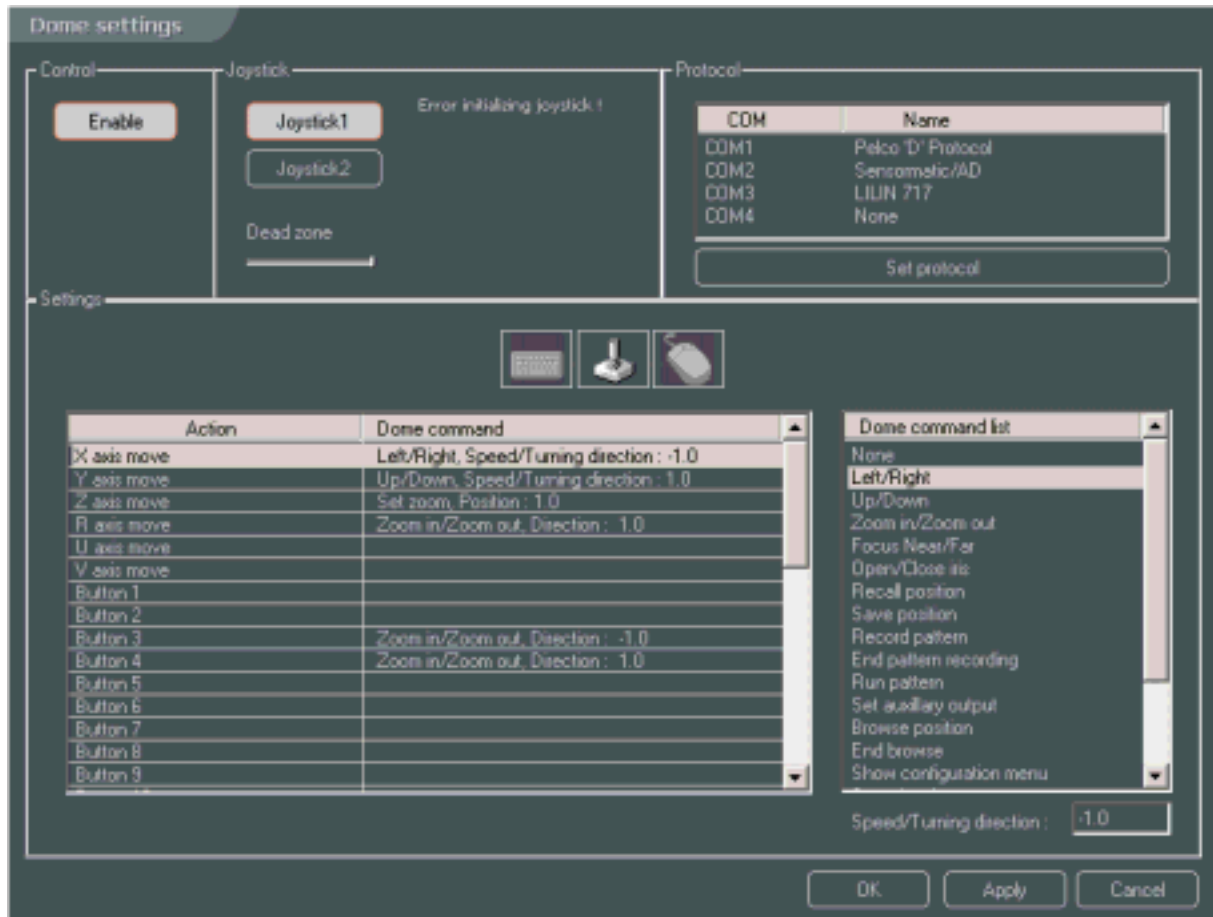

After the window is opened, select the USB joystick (at present only one joystick is supported) and select the protocol according to the type of dome to be controlled: Lilin, Sensormatic, Pelco, Telecom. If you do not have the joystick connected the message “**Error initializing the joystick**” will appear. Select the serial port, to which the RS-485 converter is connected (COM1 or COM2) and click **Set protocol** button:

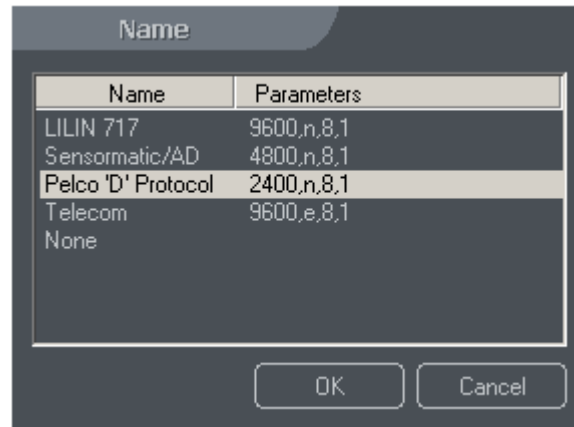

Select the protocol from the list in the window above that will be assigned to the specific serial port.



The keyboard, the joystick, and the mouse icons are used to define program behavior depending on pressing of a particular key or joystick movement.

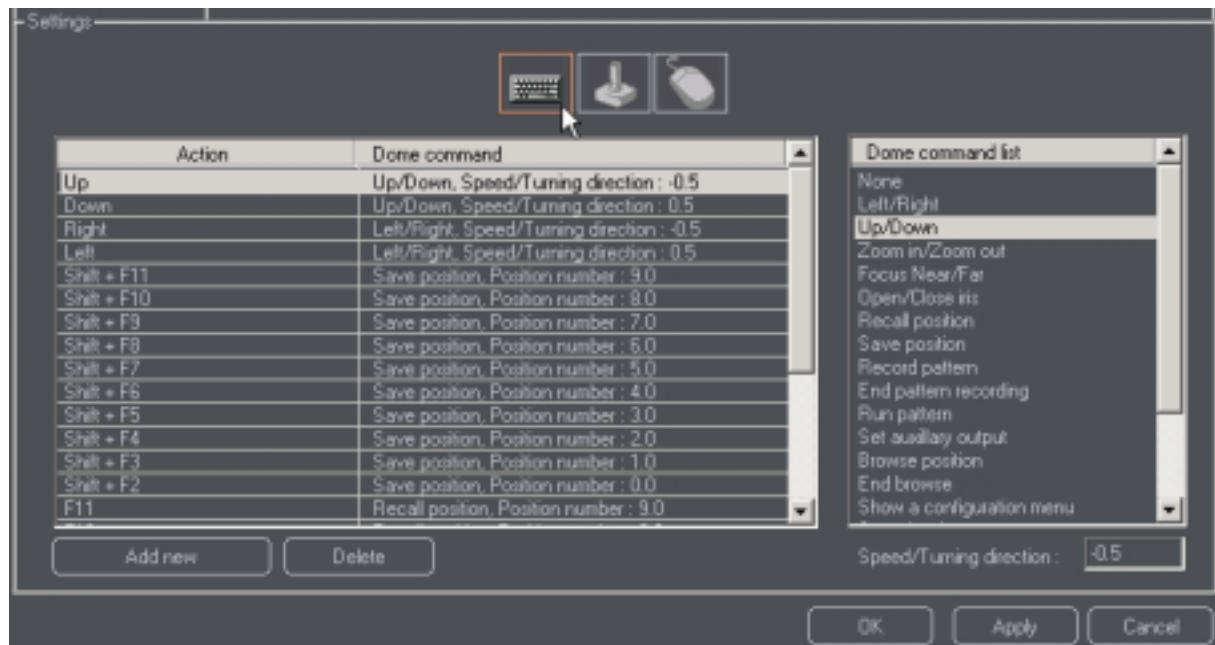

When you select the keyboard, different keys can be bound to different functions (double-click an item, or press the **Add new** button, if there are no items). Press a key on the keyboard and select a function for this key on the right, e.g. **Set position**, **Turn left**, **Turn right**. You can assign unlimited number of commands. Set the speed of rotation in range from  $-1$  to  $+1$ .

There are default keys defined for saving of the camera position (SHIFT+F2 ... SHIFT+F11) and for setting of the dome to the saved position (F2...F11).

Settings for the mouse are not working in the current version of the program. They will be defined and used in a similar way, as the keyboard and the joystick.

## 5.2 Dome control panel

Select the  icon from the icon bar on the left hand side to open the window of the screen joystick. This is useful if the analogue USB joystick is not present.



The arrows indicate directions, zoom in and zoom out options are located underneath. The turtle, man and rabbit icons determine the speed of the camera movement after an arrow is pressed. More precisely, that means that when you press an arrow, the dome will be moved by a specified interval. If the turtle icon is selected, the dome will move very slowly, the human icon causes the dome to move at medium speed and pressing the hare icon results in very fast movement of the dome.

The icons with numbers emulate pressing a joystick button, and the last icon at the bottom turns on the stepping mode.

## 6 Dongle Validation

The VideoDR-S system is protected by a hardware dongle connected to the PC's printer port (LPT) or USB port. Taking customer needs into consideration, the manufacturer introduced an evaluation period of several weeks. After that period the user will be prompted to extend the validity of the dongle. The dongle must be validated in order for the program to operate. Contact the vendor and provide the serial number obtained with the program and the special code generated by the **Dongle update** program. Below you can find instructions on how to obtain the code to be submitted to the vendor.

NOTE! Alnet products that are prepaid prior to shipment will have unlimited authorization. In the case of invoiced or products billed by the manufacturer, the program has a preset time limit of 45 days of authorization by default. Continuation procedure usually takes only a few minutes to get the answer. But to get a new authorization number to restart the system you might have to wait for a maximum of 3 day period.

To update the key, you need to select the folder from the Windows *Start* menu, specified during installation (by default it is **Start / Applications / ALNET**), and select the **Dongle update** item from the drop-down menu.



Select the first option **Whole or partial update of dongle's memory contents** to update the dongle memory (e.g. after purchasing more cards). If you wish to extend the validity of the user's key, select the second option **Continuation of the license term of the protected program**. Then follow the instructions of the dongle update program.

**NOTE!!!** Usually the update is processed within a few minutes, but in particular cases it may take up to 3 days. Therefore it is advisable to obtain an extension of validity well in advance of the expiry of the hardware dongle.

### The procedure of Continuation of validity (time limit) of the dongle.



1. After starting the dongle **update** application select the **Continuation of the license term of the protected program** option and press the **Next** button.

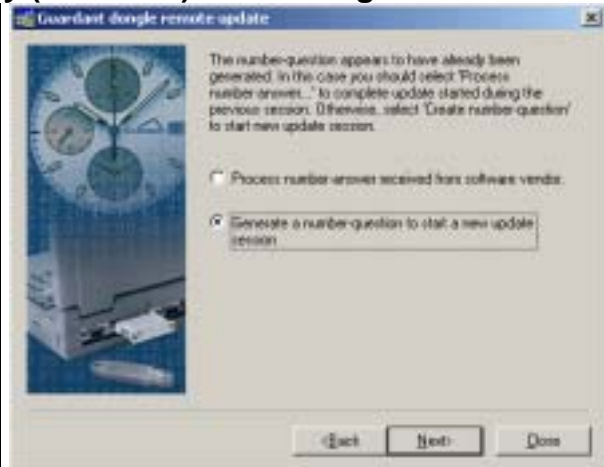

2. Select the **Generate a number-question to start a new update session** and press the **Next** button.



3. A 12-digit code will appear in the window, which should be submitted to the software vendor. On this basis a code prolonging validity of the dongle will be generated. If the procedure is processed on-line, press the **Next** button and proceed to **point 6**. If the code will be supplied later, you can finish the application and start it again in order to enter the received code.



4. Start the application again, select the **Continuation of the license term of the protected program** option, as before, and press the **Next** button.



5. This time select the **Process number-answer received from software vendor** option.

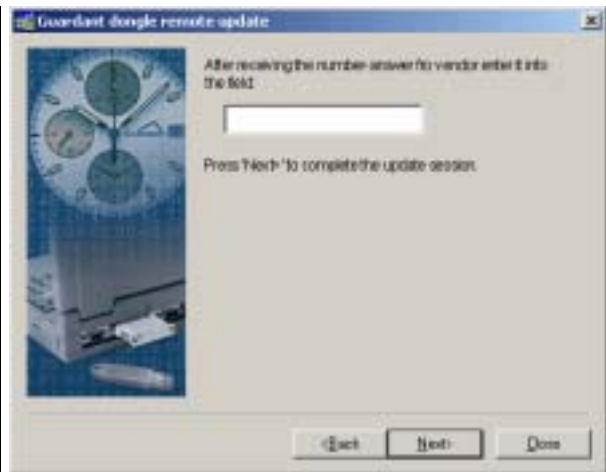

6. Enter the received code in the window and press the **Next** button. A window will appear with a message about the update of the user's validity of the dongle.

## 7 Uninstallation of the VideoDR-S system software

In order to uninstall the software go to **Start – Settings – Control Panel**. In the control panel select the **Add/Remove Programs** icon. Find the **VideoDR-S** item and press the **Change/Remove** button.

An InstallShield Wizard window will appear. Select the **Remove** option and click the **Next** button:



The InstallShield Wizard will ask if you are sure that you want to remove the software from the Windows system. Click the **OK** button to confirm.

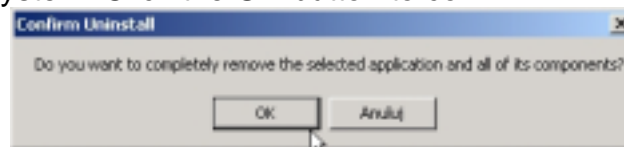

The installation program will ask if you want to remove the files of installed libraries. Checking the **Don't display this message again** option will prevent this message to appear again.

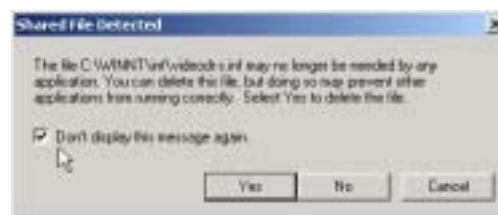

## 8 FAQ - Frequently Asked Questions

- 1) *Question:* I can't start the program, I get the following error message: “**No dongle detected**”.

*Answer:* The dongle obtained with the kit must be connected to the computer printer port (LPT) or USB port. Details on the installation of the dongle may be found in Chapter “2.2 Installation of the dongle” on page 8. Check also of the LPT port operation mode, bi-directional **ECP** communications should be configured. In order to check the currently configured mode, right-click the **My Computer** icon, select the **Properties**, then the **Hardware** tag and the **Device Manager** button expand the COM and LPT Ports device group, and there should be an **EPC Printer Port (LPT1)** item. If there is no such item, or different mode is selected, e.g. **SPP**, you would need to change the port mode in the computer **BIOS** settings. Consult the motherboard manual or contact the PC vendor for details.

If the above does not solve the problem, check the connection, and if you still get the error message, try to connect a printer and print the test page. If you cannot print, your LPT port or cables might be faulty. Contact the vendor/manufacturer of your PC.

- 2) *Question:* I can't install the video card drivers. The system tries to install some drivers with names different from those given in this manual.

*Answer:* Different video capture card might have been installed previously on that computer and its drivers are still in the system. You would have to change the video capture card driver manually. Right-click the **My Computer** icon and select the **Properties** item from the context menu, then the **Hardware** tag and the **Device Manager** button in the **System Properties** window. Check if there are any incorrect drivers in the **Sound, video and game controllers** section. Right-click the driver and select the **Properties** item, the **Driver** tag, and the **Driver update** button. In the **Device Driver Update Wizard** window select the **Display a list of known drivers...** item and press the **Next** button. Some matching drivers might be displayed. Select **ALNET VideoDR-S WDM Video Capture** or **ALNET VideoDR-S WDM Audio Capture** from the list and press the **Next** button to update the driver. Reboot the computer when update is completed.

- 3) *Question:* I'm trying to start the program and I get the following message: “**Windows NT driver must be loaded**”.

*Answer:* This message means that the dongle driver has not been installed correctly. Make sure that the dongle is plugged into the printer (LPT) port and run the program to install the dongle driver: **Start / Applications / ALNET / dongle installation**. Restart the VideoDR-S system.

- 4) *Question:* When I start the program, the following message appears: “**An error occurred when trying to open the videodrs.dll library. Image recording will not be possible**”.

*Answer:* The above message means that the drivers for the video image capture cards have not been installed correctly. It may be displayed if the system has not been rebooted after software installation. If this message occurs after rebooting of the system, check in the **Device Manager**, if there is any unrecognized device and try to update the drivers.

5) *Question:* One or more cameras are not displaying any image.

*Answer:* Check if the camera is operational, e.g. connect it to another input on the card. Ensure that the selected camera is active in the **Camera settings** (the **Connect camera** button in the **Global** frame under the camera image preview is highlighted). If those settings are correct and you do not see any picture from any camera (blue screen neither) the possible cause could be that your graphic card does not support some graphic hardware based functions the program uses. In that case you should turn off the option **Use DirectX** in **Program settings** window (Chapter 3.7).

## 9 Advanced settings

### 9.1 Tunneling

The system is adapted for running in local networks with a connection to the Internet and equipped with a proxy server / firewall with one external routable IP address. In order to “tunnel” the VideoDR-S signal (making it available under the external address of the main network server) you need to configure two tunnel lines for the dedicated TCP/IP port of the VideoDR-S service and the successive port.

#### EXAMPLE

It is assumed that:

The VideoDR-S is running in an internal network under the private IP address 192.168.1.2.

The VideoDR-S service is running on this computer at the address 44.

The network server has the external IP 212.244.103.44 and the internal IP 192.168.1.1

From the Internet level the VideoDR-S is to be available under the public IP address of our network server at the address 555.

The tunnel should have the following form:

212.244.103.44:555 -> to the local network as 192.168.1.1 to -> 192.168.1.2:44

### 9.2 Dial-up

The VideoDR-S system supports direct modem – modem connection.. It is necessary to equip the computer running the VideoDR-S system with a dial-up modem. The presented method is based on the connection sharing of the TCP/IP protocol.

Setting up a direct modem to modem connection on the server under Windows 2000 Professional operating system.

- Click **Start > Settings > Network and Dial-up connection > Create a new connection** in order to run the **Network Connection Wizard**
- Click **Next**
- Select **Accept incoming connections** and click **Next**
- Select an appropriate device for the connection (a modem) and click **Next**
- Select **Do not accept unauthorized connections** and click **Next**
- Add (if necessary) and select a valid user and click **Next**
- Select **Internet protocol** and click **Properties**
- Deactivate **Allow the caller to access my local network**
- Select **Determine TCP/IP address**
- Enter an address range (for example: from 1.1.1.1 to 1.1.1.2)
- Deactivate **Allow the caller to determine its own IP address** and click **OK**
- Click **Next**
- Enter a correct connection name and click **Finish**
- Run the VideoDR-S, run the Server from the Setup and save the system settings.
- Connecting the Client PC to the Server
- Configure a standard PC connection to the Internet.
- Establish a connection with the master computer using a dial-up connection.

- Enter the name of the master computer, user name and password
- Send the command ping 1.1.1.1, in case of success run the VideoDR-C client application and connect to 1.1.1.1

## **10 Contact info**

Alnet Systems  
ul. 3 Maja 54  
81-850 Sopot  
POLAND

tel (+48 58) 555 73 82  
tel (+48 58) 555 73 83  
tel (+48 58) 345 05 38  
tel (+48 58) 345 05 39  
fax (+48 58) 550 20 49

alnet@alnetsystems.com  
<http://www.alnetsystems.com/>